



DRAFT

FCAT 2.0 SCIENCE

Test Item Specifications

Grade 8



FLORIDA DEPARTMENT OF EDUCATION
www.fldoe.org

Copyright Statement for This Office of Assessment Publication

Authorization for reproduction of this document is hereby granted to persons acting in an official capacity within the Uniform System of Public K–12 Schools as defined in Section 1000.01(4), Florida Statutes. The copyright notice at the bottom of this page must be included in all copies.

All trademarks and trade names found in this publication are the property of their respective owners and are not associated with the publishers of this publication.

Permission is **NOT** granted for distribution or reproduction outside of the Uniform System of Public K–12 Florida Schools or for commercial distribution of the copyrighted materials without written authorization from the Florida Department of Education. Questions regarding use of these copyrighted materials should be sent to the following:

The Administrator
Office of Assessment
Florida Department of Education
Tallahassee, Florida 32399-0400

Copyright © 2010
State of Florida
Department of State

TABLE OF CONTENTS

- 1 Introduction**
 - Origin and Purpose of the *Specifications*
 - Scope of this Document
 - Overall Considerations
 - Item Contexts (Scenarios)

- 5 Criteria for FCAT 2.0 Science Test Items**
 - Use of Graphics
 - Item Style and Format
 - Scope of Test Items
 - Guidelines for Item Writers

- 10 Cognitive Complexity of FCAT 2.0 Science Test Items**
 - Item Difficulty
 - Cognitive Complexity of FCAT 2.0 Science Test Items
 - Universal Design

- 17 Review Procedures for FCAT 2.0 Science Test Items**
 - Review for Potential Bias and Community Sensitivity
 - Review of Test Items

- 18 Guide to the Individual Benchmark Specifications**
 - Benchmark Classification System
 - Definitions of Benchmark Specifications
 - Grades 3–5 FCAT 2.0 Science Benchmarks

- 33 Individual Benchmark Specifications for FCAT 2.0 Science Grade 8**

- A–1 Appendix A:** Directions for Item Review and FCAT 2.0 Science Item Rating Form

- B–1 Appendix B:** Science Content Assessed by Grade 8 FCAT 2.0 Science

- C–1 Appendix C:** FCAT 2.0 Science Item Writer Glossary, Grades 5 and 8

- D–1 Appendix D:** Periodic Table of the Elements, Grade 8 and Biology 1 End-of-Course Assessment

- E–1 Appendix E:** FCAT 2.0 Science and Biology 1 End-of-Course Assessment Test Design Summary

INTRODUCTION

In recent years, two realities focused attention on the need to reevaluate Florida's Sunshine State Standards. First, in 2005, outside consultants reviewed the 1996 Sunshine State Standards and suggested that the benchmark language offer greater specificity to indicate clearly what teachers should teach and what students should be able to do. Second, federal legislation through the *No Child Left Behind Act of 2001* (NCLB) holds schools and school districts accountable for how well each child is learning, which further emphasizes the need to hone expectations for all students.

In January 2006, the Florida Department of Education (DOE) committed to a six-year cycle of review and revision of the K–12 content standards. The science standards were rewritten, and the Next Generation Sunshine State Standards (NGSSS) for science were adopted by the Florida State Board of Education in February 2008 (available online at: <http://www.floridastandards.org/Standards/FLStandardSearch.aspx>).

For Grades K–8, the NGSSS are divided into benchmarks that identify what a student should know and be able to do at each grade level. This document, *FCAT 2.0 Science Test Item Specifications, Grade 8 (Specifications)*, provides information about the benchmarks, the stimulus types, and the test items designed to assess the standards for Grades 6–8.

The Florida Comprehensive Assessment Test 2.0® (FCAT 2.0) measures achievement of Florida students in writing, reading, mathematics, and science. End-of-course (EOC) assessments measure achievement of Florida students who have completed coursework in Algebra 1, Geometry, and U.S. History. The Biology 1 EOC Assessment measures achievement of Florida students enrolled in Biology 1, or an equivalent course, by assessing student progress on benchmarks from the NGSSS that are assigned to Biology 1 course descriptions.

Origin and Purpose of the *Specifications*

The Florida Department of Education and committees of experienced Florida educators developed and approved the *Specifications*. The *Specifications* is a resource that defines the content and format of the test and test items for item writers and reviewers. The grade-level *Specifications* indicates the alignment of test items with the NGSSS. It also serves to provide all stakeholders with information about the scope and function of the FCAT 2.0.

Scope of this Document

The *Specifications* for Grade 8 provides general and grade-specific guidelines for the development of all test items used in the FCAT 2.0 Science test for Grade 8. Two additional *Specifications* documents provide the same information for the FCAT 2.0 Science Grade 5 and the Biology 1 EOC assessments.

The Overall Considerations section in this Introduction provides an explanation of the science concepts and elements assessed by the test. The Criteria for FCAT 2.0 Science Test Items section addresses cognitive complexity levels as well as the review processes used to ensure the quality of the stimuli and test items. The same section explains the general guidelines for selection and development of multiple-choice items. The Individual Benchmark Specifications section contains specific information about each benchmark. This section provides benchmark clarification statements, content limits, stimulus attributes, response attributes, and a sample item for each benchmark grouping.

Overall Considerations

This section of the *Specifications* describes the guidelines that apply to all test items developed for the FCAT II Science Grades 5 and 8.

Overall considerations are broad item-development issues that should be addressed during the development of test items. Sections of Criteria for FCAT 2.0 Science Test Items relate more specifically to one aspect of the development (e.g., content limits, stimulus attributes).

1. Each test item should be written to measure primarily one benchmark; however, other benchmarks may also be reflected in the item context (scenario).
2. Some benchmarks are combined for assessment, and the individual specification indicates which benchmarks are combined. Test items may be written to “also assesses” benchmarks; however, the overall theme of the benchmark grouping should be evident in the items.
3. Test items should be appropriate for students in terms of grade-level instruction, experience and difficulty, cognitive development, and reading level. The reading level of the test items should be on grade level, except for specifically assessed science terms or concepts. Some words used in the Grade 5 benchmarks are above grade level. The Individual Benchmark Specifications and the Grade 5 Item Writer Glossary provide information to the writer on which science terms are appropriate for use in test items at Grade 5. For Grade 8, words found in the benchmarks and the glossary are appropriate for use in test items unless otherwise noted in the *Specifications*.
4. Test items should be written to the cognitive level of the benchmark unless otherwise noted in the individual specification sections. For example, if the benchmark states the student will compare concepts, the test item should assess a comparison.
5. Test items should assess the application of the concept rather than the memorization of science fact, law, or theory unless otherwise noted in the individual benchmark specifications.
6. Test items will not require the student to define terms.
7. Test items that include a collection of data should require the student to analyze or interpret that data (e.g., use data from a scenario to identify a trend) rather than retrieve information directly from a passage, chart, graph, or table.
8. Test items or illustrations for Grades 5 and 8 may use the following common elementary laboratory tools: balance, battery, beaker, compass, eyedropper, flashlight, globe, graduated cylinder, light bulb, magnet, magnifying glass or hand lens, metric measuring tape, metric ruler, microscope, microscope slide, mirror, model, safety goggles, spring scales, stopwatch, telescope, test tube, thermometer, topographic map, and tuning fork.
9. Test items or illustrations for Grade 8 may use the following common middle-school laboratory tools in addition to the elementary laboratory tools: dissection equipment, electronic balance, flask, hot plate, meter stick, petri dish, pH sensors, pipette, probe, prism, pulley, test strips, and triple-beam balance.

10. Test items referring to technologies familiar to elementary and middle-school students may include computers and computer models (simulations).
11. Test items will not require the creation of a chart, graph, or table.
12. At Grade 5, all test items should be written in a conceptual nature. Grade 5 test items should not require use of a calculator. At Grade 8, students are allowed to use a four-function calculator, although test items should not require its use.
13. Test items may require the student to apply knowledge of the science concepts described in the prior knowledge benchmarks from lower grades; however, that knowledge should NOT be assessed in isolation.
14. Each test item should be written clearly and unambiguously to elicit the desired response.
15. Test items will not require the memorization of equations or formulas unless otherwise noted in the Individual Benchmark Specifications. A reference sheet is not provided to students. If equations or formulas are needed, they must be included in the test item.
16. Test items will not require memorization of the Periodic Table. For Grade 8, a periodic table is provided to the students and is also found in Appendix D.
17. Test items should not disadvantage or exhibit disrespect to anyone in regard to age, gender, race, ethnicity, language, religion, socioeconomic status, disability, occupation, or geographic region.

Item Contexts (Scenarios)

The context in which a test item is presented is called the item context or scenario. Test items should be placed in a context.

1. The test item context should be designed to interest students at the tested levels. Scenarios should be appropriate for students in terms of grade-level experience and difficulty, cognitive development, and reading level.
2. The context should be directly related to the question asked. The context should lead the student cognitively to the question. Every effort should be made to keep test items as concise as possible without losing cognitive flow or missing the overall idea or concept.
3. Grade 5 scenarios in test items are limited to those familiar to an elementary student rather than global situations. Grade 8 scenarios in test items are limited to those familiar to a middle-school student rather than global situations. All test items will use age-, grade-, and experience-appropriate scenarios, graphics, diagrams, and illustrations.
4. Item contexts should not refer to students using textbooks or the Internet as resources. Item contexts should focus on the students engaging in science learning rather than reading about science. Item contexts should avoid using a simple classroom scenario.
5. Item contexts and illustrations depicting individuals conducting laboratory investigations should include proper safety equipment and model safe laboratory procedures.
6. Scenarios describing scientific investigations should model current science methodology and adhere to the Intel International Science and Engineering Fair Rules and Guidelines unless otherwise noted in the benchmark clarification statements. These rules and guidelines can be found using the Document Library link at: <http://www.societyforscience.org/ISEF>.
7. The test item content should be timely but not likely to become dated.

CRITERIA FOR FCAT 2.0 SCIENCE TEST ITEMS

All FCAT 2.0 Science test items are in multiple-choice (MC) for mat. The general specifications on pages 5 through 16 cover the following criteria for the FCAT 2.0:

- Use of Graphics
- Item Style and Format
- Scope of Test Items
- Guidelines for Item Writers
- Cognitive Complexity of FCAT 2.0 Science Test Items
- Universal Design

Use of Graphics

Graphics are used to provide both necessary and supplemental information—that is, some graphics contain information that is necessary for answering the question, while other graphics illustrate or support the context of the question. Scenarios may include diagrams, illustrations, charts, or tables, unless otherwise noted in the individual benchmark specifications.

1. Test items should not begin with art. Art in test items is always preceded by text.
2. All tables, charts, and graphs should be titled. Titles should be in all caps, boldfaced, and centered.
3. Illustrations and pictures are either titled or introduced. If a title is used, the title may be placed above or below the illustration or picture.

Item Style and Format

This section presents stylistic guidelines and for matting directions that should be followed while developing test items.

General Guidelines

1. Test items should be clear and concise and should use vocabulary and sentence structure appropriate for the assessed grade level. Writers should refer to the resources provided during item writer training and to the Glossary in the back of the *Specifications* to determine if the language used in the test item is grade-level appropriate.
2. Scientific concepts should be grade appropriate. Writers should refer to the Prior Knowledge information in the Individual Benchmark Specifications section, the instructional foundation for each benchmark grouping. For Grade 8, the Grades 3–5 benchmarks are found on pages 21–32.
3. Test items should have only one correct answer. The words *most likely* or *best* should only be used when appropriate to the question.
4. The final sentence of all test item stems must be expressed as a question.
5. At Grade 5, test items addressing temperature should use degrees Celsius with the approximate whole number equivalent in degrees Fahrenheit, e.g., 37°C (99°F). At Grade 8, temperatures should be given in degrees Celsius unless otherwise noted in the individual benchmark specifications.

6. Metric units of measure should be used in scenarios addressing mass, length, weight, and/or volume. International System of Units (SI) should be used unless otherwise noted in the individual benchmark specifications.
7. Test items requiring art should be to scale whenever possible. If not possible, a *not-to-scale* text box should be included at the bottom left of the art.
8. Graphics in test items should be clearly labeled and contain all necessary information.
9. Test items referring to new developments or discoveries should include phrases similar to *according to current knowledge* or *based on current knowledge*.
10. Test item questions using the word *not* should emphasize the word *not* using all uppercase letters (e.g., Which of the following is NOT an example of . . .).
11. As appropriate, boldface type should be used to emphasize key words in the test item question (e.g., **least**, **most**, **greatest**, **percent**, **best**).
12. Masculine pronouns should NOT be used to refer to both sexes. Name(s) should be used whenever possible to avoid gender-specific pronouns (e.g., instead of *The student will make changes so that he . . .* use *John and Maria will make changes so that they . . .*).
13. An equal balance of male and female names should be used, including names representing current student names and different ethnic groups appropriate for Florida.
14. Grade 8 test items may express values using scientific notation; however, test items should not require calculations involving scientific notation. Use of scientific notation is not appropriate at Grade 5.
15. Decimal numbers between -1 and 1 should have a leading zero.
16. SI units should be expressed in a single type of unit when possible (e.g., 1.4 kilograms instead of 1 kilogram 400 grams).
17. Decimal notation should be used for numbers with SI units (e.g., 1.5 grams instead of $1\frac{1}{2}$ grams).
18. Commas should be used in numbers greater than or equal to 1,000 except for numbers having an SI unit. In this case, numbers with four digits should be presented without a comma or a space (e.g., 9960 meters). Numbers with more than four digits should be presented with a thin space inserted in place of a comma (e.g., 10 123 kilograms).
19. The first occurrence of units of measure should be written out in the test item stem, e.g., kilograms (kg). In graphics, an abbreviation may be used (e.g., g or cm). To avoid confusion between the preposition *in* and the abbreviation for inches, only units of measure in graphics should be presented, e.g., height (cm) NOT height (in cm).
20. In titles of tables and charts and in labels for axes, the unit of measure should be included, preferably in lowercase and in parentheses, e.g., height (m).

17. If the answer options for a test item are strictly numerical, they should be arranged in ascending or descending order, with the place values of digits aligned. When the test item requires the identification of a choice from the item stem, table, chart, or illustration, the options should be arranged as they are presented in the item stem, table, chart, or illustration.
18. If the answer options for a test item are neither strictly numerical nor denominator numbers, the options should be arranged by the logic presented in the test item, by alphabetical order, or by length. Options may also be ordered in reverse alphabetical order or from longest to shortest. Answers that are one word in length should be in alphabetical or reverse alphabetical order.

Context-Dependent (CD) Item Sets

1. The stimulus for the CD set may be a **short** passage describing a scientific event or investigation. The stimulus may include illustrations, graphics, tables, and/or graphs.
2. As a general rule the stimulus content should focus on primarily two science areas from the NGSSS (Nature of Science, Earth and Space Science, Life Science, or Physical Science).
3. The reading level of the stimulus, excluding science terms, should be on grade level.
4. Test items will be written so that students with benchmark mastery use scientific knowledge and the information in the passage to answer the test items in the set.
5. Test items will not be clued or answered by information in the passage or other test items in the set.
6. Test items may require the student to analyze, interpret, evaluate, and/or draw inferences from the information in the stimulus.
7. As many test items as possible should be written to the stimulus. Those test items should represent an appropriate variety of benchmarks. On a test, a minimum of two different benchmarks should be assessed in the CD set.
8. CD sets may be titled; however, titles are not required.

Scope of Test Items

The scope of FCAT 2.0 Science test items for Grades 6–8 is presented in Appendix B. The benchmarks serve as the objectives to which the test items are written. Additional guidelines or restrictions are located in the individual benchmark specifications.

Guidelines for Item Writers

FCAT 2.0 Science item writers must have a comprehensive knowledge of the assessed science curriculum and a strong understanding of the scientific concepts and cognitive abilities of the students taking the test. Item writers should know and consistently apply the guidelines established in this *Specifications* document, as well as contribute to the goal of developing test content that allows students to perform at their best. Item writers are also expected to use their best judgment in writing test items that measure the science benchmarks of the NGSSS without introducing extraneous elements that reflect bias for or against a group of students.

Item writers for FCAT 2.0 Science must submit test items in a particular format and must include the following information about each test item. Because test items are rated by committees of Florida educators following submission to DOE, familiarity with the directions for rating test items (found in Appendix A) would prove useful to all item writers.

Format	Item writers must submit test items in the agreed-upon template. All appropriate sections of the template should be completed before the test items are submitted.
Sources	Item writers are expected to provide sources for all verifiable information included in the test item. Acceptable sources include science magazines, science journals, or Internet sites maintained by reputable organizations such as government agencies, universities, or research centers.
Correct Response	Item writers must supply the correct response. Each distractor should be a believable answer for someone who does not know the correct answer. Rationales must include explanations for these errors.
Submission of Items	When submitting test items, item writers must balance several factors. Test item submissions should: <ul style="list-style-type: none">• include test items of varying difficulty;• include test items of varying cognitive complexity;• include test items from varying content foci;• include the content source for the test items;• have a balance in location of the correct answer within benchmarks;• have a balance of different female and different male names;• use names representative of elementary and middle-school students in Florida; and• be scientifically accurate.

COGNITIVE COMPLEXITY OF FCAT 2.0 SCIENCE TEST ITEMS

Educational standards and assessments can be aligned based on the category of content covered and also on the complexity of knowledge required. The FCAT 2.0 test items, while assessing Florida's NGSSS, must also reflect this goal and standard. It is important to develop test items that elicit student responses that demonstrate the complexity of knowledge and skills required to meet these objectives. The degree of challenge of FCAT 2.0 items is currently categorized in two ways: **item difficulty** and **cognitive complexity**.

Item Difficulty

The difficulty of FCAT 2.0 items is initially estimated by committees of educators participating in Item Content Review meetings each year. As each test item is reviewed, committee members make a prediction of difficulty based upon their knowledge of student performance at the given grade level. The classification scheme used for this prediction of item difficulty is based on the following:

- | | |
|--------------------|--|
| Easy | More than 70 percent of the students are likely to respond correctly. |
| Average | Between 40 percent and 70 percent of the students are likely to respond correctly. |
| Challenging | Less than 40 percent of the students are likely to respond correctly. |

After a test item appears on a test, item difficulty refers to the actual percentage of students who chose the correct answer.

Cognitive Complexity of FCAT 2.0 Science Test Items

Cognitive complexity refers to the cognitive demand associated with a test item. In the early years of the FCAT program, DOE used Bloom's Taxonomy¹ to classify test items; however, Bloom's Taxonomy is difficult to use because it requires an inference about the skill, knowledge, and background of the students responding to the test item. Beginning in 2004, DOE implemented a new cognitive classification system based upon Dr. Norman L. Webb's Depth of Knowledge (DOK) levels.² The rationale for classifying a test item by its DOK level of complexity focuses on the *expectations made of the test item*, not on the *ability of the student*. When classifying a test item's demands on thinking (i.e., what the test item requires the student to recall, understand, analyze, and do), it is assumed that the student is familiar with the basic concepts of the task. Test items are chosen for the FCAT 2.0 based on the NGSSS and their grade-level appropriateness, but the complexity of the test items remains independent of the particular curriculum a student has experienced. On any given assessment, the cognitive complexity of a multiple-choice item may be affected by the distractors (answer options). The cognitive complexity of a test item depends on the grade level of the assessment; a test item that has a high level of cognitive complexity at one grade may not be as complex at a higher grade.

The categories—low complexity, moderate complexity, and high complexity—form an ordered description of the demands a test item may make on a student. For example, low-complexity test items may require a student to solve a one-step problem. Moderate-complexity test items may require multiple steps. High-complexity test items may require a student to analyze and synthesize information. The distinctions made in item complexity ensure that test items will assess the depth of student knowledge at each benchmark. The intent of the item writer weighs heavily in determining the complexity of a test item. At the end of this section, three FCAT 2.0 Science test items illustrate how a single concept may be assessed by test items with increasing cognitive complexity.

The pages that follow illustrate some of the varying demands that test items might make at each complexity level for FCAT 2.0 Science. Note that test items may fit one or more descriptions. In most instances, these test items are classified in the highest level of complexity demanded by the test item. Caution must be used in referring to the table of descriptors that is provided for each cognitive complexity level. This table is provided for ease of reference, but the ultimate determination of item complexity should be made considering the overall cognitive demand placed on a student. Another table provides the breakdown of the percentage of points by cognitive complexity level.

¹ Bloom, B.S. et al. *Taxonomy of Educational Objectives, Handbook I: Cognitive Domain*. New York: McKay, 1956.

² Webb, Norman L. and others. "Web Alignment Tool" 24 July 2005. Wisconsin Center of Educational Research. University of Wisconsin-Madison. 2 Feb. 2006. <http://www.wcer.wisc.edu/WAT/index.aspx>.

Low Complexity

Science low-complexity test items rely heavily on the recall and recognition of previously learned concepts and principles. Test items typically specify what the student is to do, which often is to carry out some procedure that can be performed mechanically. It is not left to the student to come up with an original method or solution.

Felipe and Marsha were studying forces and decided to do an experiment. They placed four equally sized blocks made of different materials on an elevated plastic tray. They watched the blocks move down the tray. Their setup is shown below.

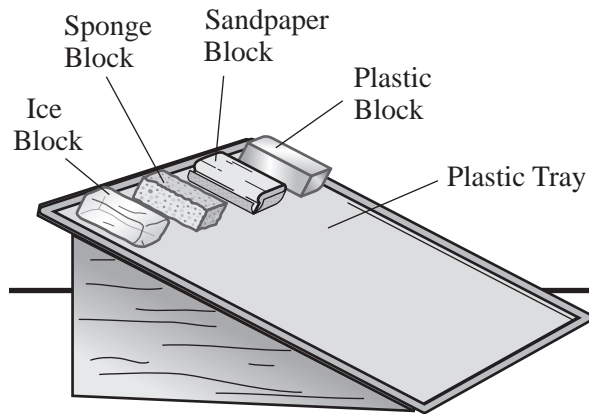

Which of the following forces causes the blocks to move down the tray?

- A. electric
- B. friction
- ★ C. gravity
- D. magnetic

Moderate Complexity

Science moderate-complexity test items involve more flexible thinking than low-complexity test items do. They require a response that goes beyond the habitual, is not specified, and ordinarily involves more than a single step or thought process. The student is expected to decide what to do—using informal methods of reasoning and problem-solving strategies—and to bring together skill and knowledge from various domains.

Felipe and Marsha were studying forces and decided to do an experiment. They placed four equally sized blocks made of different materials on an elevated plastic tray. They watched the blocks move down the tray. Their setup is shown below.

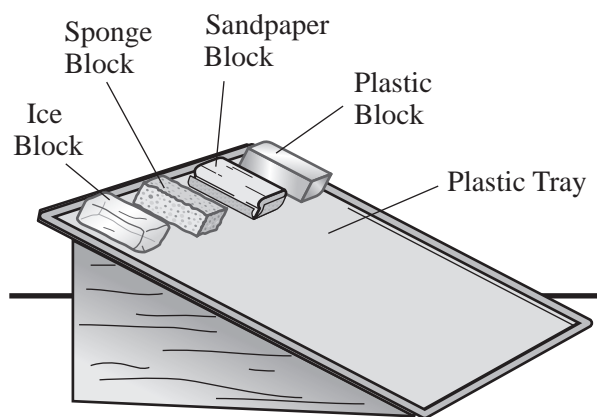

Which block would experience the **least** amount of friction as it moved down the tray?

- ★ A. Ice Block
- B. Sponge Block
- C. Sandpaper Block
- D. Plastic Block

High Complexity

Science high-complexity test items make heavy demands on student thinking. Students must engage in abstract reasoning, planning, analysis, judgment, and creative thought. The test items require that the student think in an abstract and sophisticated way, often involving multiple steps.

Felipe and Marsha were studying forces and decided to do an experiment. They placed four equally sized blocks made of different materials on an elevated plastic tray. They watched the blocks move down the tray. Their setup is shown below.

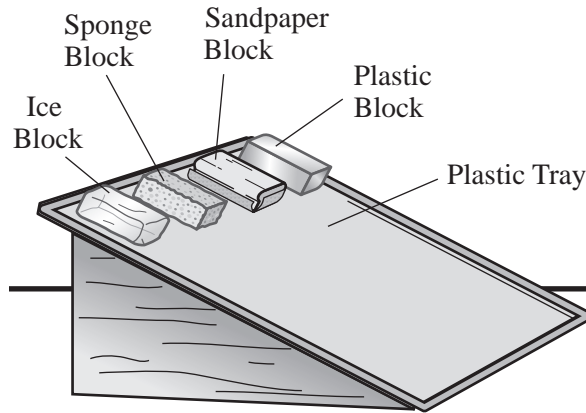

Which of the following conclusions can Felipe and Marsha make about the forces that cause the blocks to move down the tray?

- A. The force of friction is the same on each block.
- B. The force of friction causes the speed of each block to increase.
- C. The force of gravity causes all the blocks to move at the same speed.
- ★ D. The force of gravity is greater than the force of friction on all the blocks.

The following table is provided for ease of reference; however, caution must be used in referring to this table of descriptors for each cognitive complexity level. The ultimate determination of an item’s cognitive complexity should be made considering the intent of the overall cognitive demand placed on a student.

Examples of FCAT 2.0 Science Activities across Cognitive Complexity Levels		
Low-Complexity Science	Moderate-Complexity Science	High-Complexity Science
<ul style="list-style-type: none"> • Identify a common example or recognize a concept. • Retrieve information from a chart, table, diagram, or graph. • Recognize a standard scientific representation of a simple phenomenon. • Calculate or complete a familiar single-step procedure or equation using a reference sheet. 	<ul style="list-style-type: none"> • Apply or infer relationships among facts, terms, properties, or variables. • Describe examples and non-examples of scientific processes or concepts. • Predict or determine the logical next step or outcome. • Compare or contrast structures or functions of different organisms or systems. • Choose the appropriate formula or equation to solve a problem and then solve it. • Apply and use concepts from a standard scientific model or theory. 	<ul style="list-style-type: none"> • Construct models for research. • Generalize or draw conclusions. • Design an experiment, given data and conditions. • Explain or solve a problem in more than one way. • Provide a justification for steps in a solution or process. • Analyze an experiment to identify a flaw and propose a method for correcting it. • Interpret, explain, or solve a problem involving complex spatial relationships. • Predict a long-term effect, outcome, or result of a change within a system.

The table below presents the range for the percent of raw score points by cognitive complexity on FCAT 2.0 Science, Grade 5 and Grade 8, and the Biology 1 EOC Assessment.

**Percentage of Points by Cognitive Complexity Level for
FCAT 2.0 Science and Biology 1 EOC Assessment**

Grade	Low	Moderate	High
5	10%–20%	60%–80%	10%–20%
8	10%–20%	60%–80%	10%–20%
Biology 1	10%–20%	60%–80%	10%–20%

Universal Design

The application of universal design principles helps develop assessments that are usable to the greatest number of test takers, including students with disabilities and nonnative speakers of English. To support the goal of providing access to all students, the test maximizes readability, legibility, and compatibility with accommodations, and test development includes a review for potential bias and sensitivity issues.

DOE trains both internal and external reviewers to revise test items, allowing for the widest possible range of student participation. Item writers must attend to the best practices suggested by universal design including, but not limited to,

- reduction in wordiness;
- avoidance of ambiguity;
- selection of reader-friendly construction and terminology; and
- consistently applied concept names and graphic conventions.

Universal design principles also inform decisions about test layout and design including, but not limited to, type size, line length, spacing, and graphics.

REVIEW PROCEDURES FOR FCAT 2.0 SCIENCE TEST ITEMS

Prior to appearing on any FCAT 2.0, all science test items must pass several levels of review as part of the FCAT 2.0 development process. Florida educators and citizens, in conjunction with DOE and FCAT 2.0 contractors, scrutinize all material related to test items prior to accepting it for placement on the tests.

Review for Potential Bias and Community Sensitivity

Science test items are reviewed by groups of Florida educators generally representative of Florida's geographic regions and culturally diverse population. Test items are reviewed for the following kinds of bias: gender, racial, ethnic, linguistic, religious, geographic, and socioeconomic. Item reviews also include consideration of issues related to individuals with disabilities.

Florida citizens associated with a variety of organizations and institutions review all test items for issues of potential concern to members of the community at large. The purpose for this review is to ensure that the primary purpose of assessing science achievement is not undermined by inadvertently including in the test any material that parents and other stakeholders may deem inappropriate. Reviewers are asked to consider the variety of cultural, regional, philosophical, political, and religious backgrounds throughout Florida and to determine whether the subject matter will be acceptable to Florida students, their parents, and other members of Florida communities. Test items are written to meet FCAT 2.0 criteria and to measure the content in the NGSSS for science.

Review of Test Items

The DOE and FCAT 2.0 contractors review all test items during the item development process.

Groups of Florida science educators are subsequently convened to review the test items for content characteristics and item specifications. The content review focuses on validity, determining whether each test item is a valid measure of the designated NGSSS benchmark, as defined by grade-level specifications for test items. Separate reviews for bias and sensitivity issues are also conducted as noted above.

Due to the theory-based nature of the content area, all potential science test items undergo an extra level of scrutiny. A committee of university-level science researchers, university-level faculty, and practicing scientists from the private sector reviews the test items to ensure the accuracy and currency of the science content.

GUIDE TO THE INDIVIDUAL BENCHMARK SPECIFICATIONS

Benchmark Classification System

Each benchmark in the NGSSS is labeled with a system of numbers and letters.

- The two letters in the *first position* of the code identify the **Subject Area**.
- The number(s) in the *second position* represent the **Grade Level** to which the benchmark belongs.
- The letter in the *third position* represents the **Body of Knowledge** to which the benchmark belongs.
- The number in the *fourth position* represents the **Big Idea**.
- The number in the *last position* identifies the specific **Benchmark** under the Big Idea.

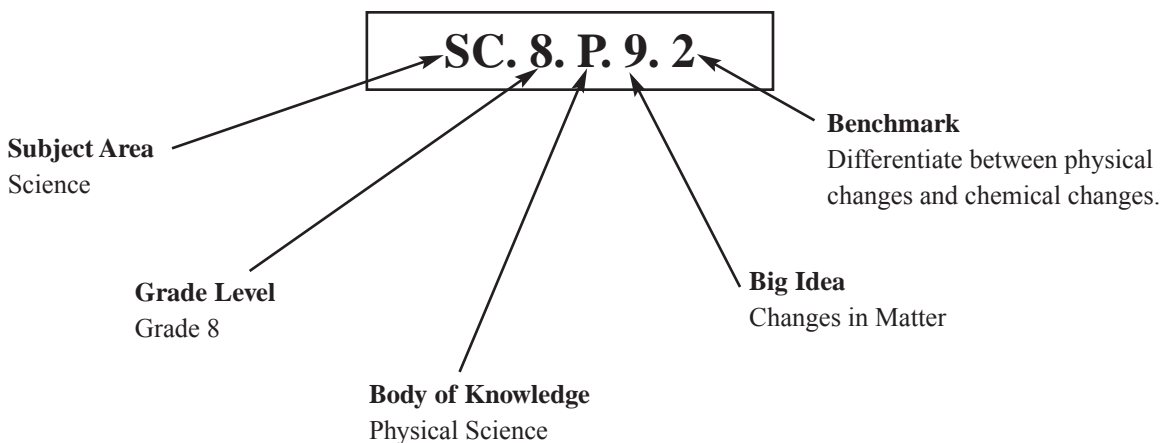

Grade 8
Body of Knowledge Physical Science
Big Idea 9 Changes in Matter
SC.8.P.9.2 Differentiate between physical changes and chemical changes.

Definitions of Benchmark Specifications

The *Specifications* identifies how the benchmarks in Florida’s NGSSS are assessed on the FCAT 2.0 at Grades 5 and 8. For each benchmark assessed in science, the following information is provided in the Individual Benchmarks Specifications section.

Reporting Categories	are groupings of related benchmarks from the NGSSS that are used to summarize and report achievement for FCAT 2.0 Science. There are four reporting categories for Grades 5 and 8 FCAT 2.0 Science: Nature of Science, Earth and Space Science, Physical Science, and Life Science.
Standard	refers to the standards statement presented in the NGSSS. In the <i>Specifications</i> for Grades 5 and 8, the standard also includes the Big Idea.
Benchmark	refers to the benchmark statement presented in the NGSSS. The benchmarks are specific statements of expected student achievement. The benchmarks are different for each Grade K–8. In some cases, two or more benchmarks are grouped together because of the relatedness of the concepts in those benchmarks. The related benchmarks are noted in the Also Assesses section.
Also Assesses	refers to the benchmarks that are closely related to the benchmark (see description above).
Benchmark Clarifications	explain how achievement of the benchmark will be demonstrated by students. Clarification statements are written for the benchmark and the also assesses benchmark(s). The clarification statements explain what students are expected to do when responding to the question.
Content Limits	<p>define the range of content knowledge and degree of difficulty that should be assessed in the test items for the benchmark.</p> <p>Benchmark content limits are to be used in conjunction with the Overall Considerations, Item Contexts, and the General Guidelines of the Item Style and Format sections in the <i>Specifications</i>. The content limits defined in the Individual Benchmark Specifications section may be an expansion or further restriction of the Overall Considerations, Item Contexts, and the General Guidelines.</p>
Stimulus Attributes	define the types of stimulus materials that should be used in the test items, including the appropriate use of item context, content, or graphic materials.
Response Attributes	define the characteristics of the options from which a student must choose to answer the question.

Prior Knowledge

refers to benchmarks from lower grades that are the foundation for the concept(s) assessed. Test items may require the student to apply scientific knowledge described in the NGSSS from lower grades; however, test items should be written to assess the appropriate grade-level benchmark.

Sample Items

are provided for each assessed benchmark grouping. The sample test items are presented in a format similar to the one used in the test. The correct answer for each sample test item is identified with a star. The benchmark that the sample item is written to assess is provided. The sample items provided represent a range of cognitive complexities.

GRADES 3–5 FCAT 2.0 SCIENCE BENCHMARKS

The Standards for science are organized by grade level K–8. Although eighteen Big Ideas thread throughout all grade levels and build in rigor and depth as students advance, not all grades have benchmarks for each Big Idea. The benchmarks for Grades 3–5 serve as a foundation for the Grades 6–8 benchmarks. For that reason, the Grades 3–5 science benchmarks are included in this document. In the Individual Benchmark Specifications section for Grade 8, Grades 3–5 benchmarks are cited in the Prior Knowledge section of the individual benchmark specifications.

Big Idea 1 The Practice of Science		
Grade 3	Grade 4	Grade 5
<p>SC.3.N.1.1 Raise questions about the natural world, investigate them individually and in teams through free exploration and systematic investigations, and generate appropriate explanations based on those explorations.</p>	<p>SC.4.N.1.1 Raise questions about the natural world, use appropriate reference materials that support understanding to obtain information (identifying the source), conduct both individual and team investigations through free exploration and systematic investigations, and generate appropriate explanations based on those explorations.</p>	<p>SC.5.N.1.1 Define a problem, use appropriate reference materials to support scientific understanding, plan and carry out scientific investigations of various types such as: systematic observations, experiments requiring the identification of variables, collecting and organizing data, interpreting data in charts, tables, and graphics, analyze information, make predictions, and defend conclusions.</p>
<p>SC.3.N.1.2 Compare the observations made by different groups using the same tools and seek reasons to explain the differences across groups.</p>	<p>SC.4.N.1.2 Compare the observations made by different groups using multiple tools and seek reasons to explain the differences across groups.</p>	<p>SC.5.N.1.2 Explain the difference between an experiment and other types of scientific investigation.</p>
<p>SC.3.N.1.3 Keep records as appropriate, such as pictorial, written, or simple charts and graphs, of investigations conducted.</p>	<p>SC.4.N.1.3 Explain that science does not always follow a rigidly defined method (“the scientific method”) but that science does involve the use of observations and empirical evidence.</p>	<p>SC.5.N.1.3 Recognize and explain the need for repeated experimental trials.</p>
<p>SC.3.N.1.4 Recognize the importance of communication among scientists.</p>	<p>SC.4.N.1.4 Attempt reasonable answers to scientific questions and cite evidence in support.</p>	<p>SC.5.N.1.4 Identify a control group and explain its importance in an experiment.</p>

GRADES 3–5 FCAT 2.0 SCIENCE BENCHMARKS

Big Idea 1 The Practice of Science		
Grade 3	Grade 4	Grade 5
<p>SC.3.N.1.5 Recognize that scientists question, discuss, and check each others' evidence and explanations.</p>	<p>SC.4.N.1.5 Compare the methods and results of investigations done by other classmates.</p>	<p>SC.5.N.1.5 Recognize and explain that authentic scientific investigation frequently does not parallel the steps of “the scientific method.”</p>
<p>SC.3.N.1.6 Infer based on observation.</p>	<p>SC.4.N.1.6 Keep records that describe observations made, carefully distinguishing actual observations from ideas and inferences about the observations.</p>	<p>SC.5.N.1.6 Recognize and explain the difference between personal opinion/interpretation and verified observation.</p>
<p>SC.3.N.1.7 Explain that empirical evidence is information, such as observations or measurements, that is used to help validate explanations of natural phenomena.</p>	<p>SC.4.N.1.7 Recognize and explain that scientists base their explanations on evidence.</p>	
	<p>SC.4.N.1.8 Recognize that science involves creativity in designing experiments.</p>	
Big Idea 2 The Characteristics of Scientific Knowledge		
Grade 3	Grade 4	Grade 5
	<p>SC.4.N.2.1 Explain that science focuses solely on the natural world.</p>	<p>SC.5.N.2.1 Recognize and explain that science is grounded in empirical observations that are testable; explanation must always be linked with evidence.</p>
		<p>SC.5.N.2.2 Recognize and explain that when scientific investigations are carried out, the evidence produced by those investigations should be replicable by others.</p>

GRADES 3–5 FCAT 2.0 SCIENCE BENCHMARKS

Big Idea 3 The Role of Theories, Laws, Hypotheses, and Models		
Grade 3	Grade 4	Grade 5
<p>SC.3.N.3.1 Recognize that words in science can have different or more specific meanings than their use in everyday language; for example, energy, cell, heat/cold, and evidence.</p>	<p>SC.4.N.3.1 Explain that models can be three dimensional, two dimensional, an explanation in your mind, or a computer model.</p>	
<p>SC.3.N.3.2 Recognize that scientists use models to help understand and explain how things work.</p>		
<p>SC.3.N.3.3 Recognize that all models are approximations of natural phenomena; as such, they do not perfectly account for all observations.</p>		
Big Idea 4 Science and Society		
Grade 3	Grade 4	Grade 5
Big Idea 5 Earth in Space and Time		
Grade 3	Grade 4	Grade 5
<p>SC.3.E.5.1 Explain that stars can be different; some are smaller, some are larger, and some appear brighter than others; all except the Sun are so far away that they look like points of light.</p>	<p>SC.4.E.5.1 Observe that the patterns of stars in the sky stay the same although they appear to shift across the sky nightly, and different stars can be seen in different seasons.</p>	<p>SC.5.E.5.1 Recognize that a galaxy consists of gas, dust, and many stars, including any objects orbiting the stars. Identify our home galaxy as the Milky Way.</p>
<p>SC.3.E.5.2 Identify the Sun as a star that emits energy; some of it in the form of light.</p>	<p>SC.4.E.5.2 Describe the changes in the observable shape of the moon over the course of about a month.</p>	<p>SC.5.E.5.2 Recognize the major common characteristics of all planets and compare/contrast the properties of inner and outer planets.</p>

GRADES 3–5 FCAT 2.0 SCIENCE BENCHMARKS

Big Idea 5 Earth in Space and Time		
Grade 3	Grade 4	Grade 5
<p>SC.3.E.5.3 Recognize that the Sun appears large and bright because it is the closest star to Earth.</p>	<p>SC.4.E.5.3 Recognize that Earth revolves around the Sun in a year and rotates on its axis in a 24-hour day.</p>	<p>SC.5.E.5.3 Distinguish among the following objects of the Solar System — Sun, planets, moons, asteroids, comets — and identify Earth’s position in it.</p>
<p>SC.3.E.5.4 Explore the Law of Gravity by demonstrating that gravity is a force that can be overcome.</p>	<p>SC.4.E.5.4 Relate that the rotation of Earth (day and night) and apparent movements of the Sun, Moon, and stars are connected.</p>	
<p>SC.3.E.5.5 Investigate that the number of stars that can be seen through telescopes is dramatically greater than those seen by the unaided eye.</p>	<p>SC.4.E.5.5 Investigate and report the effects of space research and exploration on the economy and culture of Florida.</p>	
Big Idea 6 Earth Structures		
Grade 3	Grade 4	Grade 5
<p>SC.3.E.6.1 Demonstrate that radiant energy from the Sun can heat objects and when the Sun is not present, heat may be lost.</p>	<p>SC.4.E.6.1 Identify the three categories of rocks: igneous, (formed from molten rock); sedimentary (pieces of other rocks and fossilized organisms); and metamorphic (formed from heat and pressure).</p>	
	<p>SC.4.E.6.2 Identify the physical properties of common earth-forming minerals, including hardness, color, luster, cleavage, and streak color, and recognize the role of minerals in the formation of rocks.</p>	

GRADES 3–5 FCAT 2.0 SCIENCE BENCHMARKS

Big Idea 6 Earth Structures		
Grade 3	Grade 4	Grade 5
	<p>SC.4.E.6.3 Recognize that humans need resources found on Earth and that these are either renewable or nonrenewable.</p>	
	<p>SC.4.E.6.4 Describe the basic differences between physical weathering (breaking down of rock by wind, water, ice, temperature change, and plants) and erosion (movement of rock by gravity, wind, water, and ice).</p>	
	<p>SC.4.E.6.5 Investigate how technology and tools help to extend the ability of humans to observe very small things and very large things.</p>	
	<p>SC.4.E.6.6 Identify resources available in Florida (water, phosphate, oil, limestone, silicon, wind, and solar energy).</p>	
Big Idea 7 Earth Systems and Patterns		
Grade 3	Grade 4	Grade 5
		<p>SC.5.E.7.1 Create a model to explain the parts of the water cycle. Water can be a gas, a liquid, or a solid and can go back and forth from one state to another.</p>

GRADES 3–5 FCAT 2.0 SCIENCE BENCHMARKS

Big Idea 7 Earth Systems and Patterns		
Grade 3	Grade 4	Grade 5
		<p>SC.5.E.7.2 Recognize that the ocean is an integral part of the water cycle and is connected to all of Earth’s water reservoirs via evaporation and precipitation processes.</p>
		<p>SC.5.E.7.3 Recognize how air temperature, barometric pressure, humidity, wind speed and direction, and precipitation determine the weather in a particular place and time.</p>
		<p>SC.5.E.7.4 Distinguish among the various forms of precipitation (rain, snow, sleet, and hail), making connections to the weather in a particular place and time.</p>
		<p>SC.5.E.7.5 Recognize that some of the weather-related differences, such as temperature and humidity, are found among different environments, such as swamps, deserts, and mountains.</p>
		<p>SC.5.E.7.6 Describe characteristics (temperature and precipitation) of different climate zones as they relate to latitude, elevation, and proximity to bodies of water.</p>

GRADES 3–5 FCAT 2.0 SCIENCE BENCHMARKS

Big Idea 7 Earth Systems and Patterns		
Grade 3	Grade 4	Grade 5
		SC.5.E.7.7 Design a family preparedness plan for natural disasters and identify the reasons for having such a plan.
Big Idea 8 Properties of Matter		
Grade 3	Grade 4	Grade 5
SC.3.P.8.1 Measure and compare temperatures of various samples of solids and liquids.	SC.4.P.8.1 Measure and compare objects and materials based on their physical properties including: mass, shape, volume, color, hardness, texture, odor, taste, attraction to magnets.	SC.5.P.8.1 Compare and contrast the basic properties of solids, liquids, and gases, such as mass, volume, color, texture, and temperature.
SC.3.P.8.2 Measure and compare the mass and volume of solids and liquids.	SC.4.P.8.2 Identify properties and common uses of water in each of its states.	SC.5.P.8.2 Investigate and identify materials that will dissolve in water and those that will not and identify the conditions that will speed up or slow down the dissolving process.
SC.3.P.8.3 Compare materials and objects according to properties such as size, shape, color, texture, and hardness.	SC.4.P.8.3 Explore the Law of Conservation of Mass by demonstrating that the mass of a whole object is always the same as the sum of the masses of its parts.	SC.5.P.8.3 Demonstrate and explain that mixtures of solids can be separated based on observable properties of their parts such as particle size, shape, color, and magnetic attraction.
	SC.4.P.8.4 Investigate and describe that magnets can attract magnetic materials and attract and repel other magnets.	SC.5.P.8.4 Explore the scientific theory of atoms (also called atomic theory) by recognizing that all matter is composed of parts that are too small to be seen without magnification.

GRADES 3–5 FCAT 2.0 SCIENCE BENCHMARKS

Big Idea 9 Changes in Matter		
Grade 3	Grade 4	Grade 5
<p>SC.3.P.9.1 Describe the changes water undergoes when it changes state through heating and cooling by using familiar scientific terms such as melting, freezing, boiling, evaporation, and condensation.</p>	<p>SC.4.P.9.1 Identify some familiar changes in materials that result in other materials with different characteristics, such as decaying animal or plant matter, burning, rusting, and cooking.</p>	<p>SC.5.P.9.1 Investigate and describe that many physical and chemical changes are affected by temperature.</p>
Big Idea 10 Forms of Energy		
Grade 3	Grade 4	Grade 5
<p>SC.3.P.10.1 Identify some basic forms of energy such as light, heat, sound, electrical, and mechanical.</p>	<p>SC.4.P.10.1 Observe and describe some basic forms of energy, including light, heat, sound, electrical, and the energy of motion.</p>	<p>SC.5.P.10.1 Investigate and describe some basic forms of energy, including light, heat, sound, electrical, chemical, and mechanical.</p>
<p>SC.3.P.10.2 Recognize that energy has the ability to cause motion or create change.</p>	<p>SC.4.P.10.2 Investigate and describe that energy has the ability to cause motion or create change.</p>	<p>SC.5.P.10.2 Investigate and explain that energy has the ability to cause motion or create change.</p>
<p>SC.3.P.10.3 Demonstrate that light travels in a straight line until it strikes an object or travels from one medium to another.</p>	<p>SC.4.P.10.3 Investigate and explain that sound is produced by vibrating objects and that pitch depends on how fast or slow the object vibrates.</p>	<p>SC.5.P.10.3 Investigate and explain that an electrically-charged object can attract an uncharged object and can either attract or repel another charged object without any contact between the objects.</p>
<p>SC.3.P.10.4 Demonstrate that light can be reflected, refracted, and absorbed.</p>	<p>SC.4.P.10.4 Describe how moving water and air are sources of energy and can be used to move things.</p>	<p>SC.5.P.10.4 Investigate and explain that electrical energy can be transformed into heat, light, and sound energy, as well as the energy of motion.</p>

GRADES 3–5 FCAT 2.0 SCIENCE BENCHMARKS

Big Idea 11 Energy Transfer and Transformations		
Grade 3	Grade 4	Grade 5
<p>SC.3.P.11.1 Investigate, observe, and explain that things that give off light often also give off heat.</p>	<p>SC.4.P.11.1 Recognize that heat flows from a hot object to a cold object and that heat flow may cause materials to change temperature.</p>	<p>SC.5.P.11.1 Investigate and illustrate the fact that the flow of electricity requires a closed circuit (a complete loop).</p>
<p>SC.3.P.11.2 Investigate, observe, and explain that heat is produced when one object rubs against another, such as rubbing one’s hands together.</p>	<p>SC.4.P.11.2 Identify common materials that conduct heat well or poorly.</p>	<p>SC.5.P.11.2 Identify and classify materials that conduct electricity and materials that do not.</p>
Big Idea 12 Motion of Objects		
Grade 3	Grade 4	Grade 5
	<p>SC.4.P.12.1 Recognize that an object in motion always changes its position and may change its direction.</p>	
	<p>SC.4.P.12.2 Investigate and describe that the speed of an object is determined by the distance it travels in a unit of time and that objects can move at different speeds.</p>	
Big Idea 13 Forces and Changes in Motion		
Grade 3	Grade 4	Grade 5
		<p>SC.5.P.13.1 Identify familiar forces that cause objects to move, such as pushes or pulls, including gravity acting on falling objects.</p>
		<p>SC.5.P.13.2 Investigate and describe that the greater the force applied to it, the greater the change in motion of a given object.</p>

GRADES 3–5 FCAT 2.0 SCIENCE BENCHMARKS

Big Idea 13 Forces and Changes in Motion		
Grade 3	Grade 4	Grade 5
		<p>SC.5.P.13.3 Investigate and describe that the more mass an object has, the less effect a given force will have on the object’s motion.</p>
		<p>SC.5.P.13.4 Investigate and explain that when a force is applied to an object but it does not move, it is because another opposing force is being applied by something in the environment so that the forces are balanced.</p>
Big Idea 14 Organization and Development of Living Organisms		
Grade 3	Grade 4	Grade 5
<p>SC.3.L.14.1 Describe structures in plants and their roles in food production, support, water and nutrient transport, and reproduction.</p>		<p>SC.5.L.14.1 Identify the organs in the human body and describe their functions, including the skin, brain, heart, lungs, stomach, liver, intestines, pancreas, muscles and skeleton, reproductive organs, kidneys, bladder, and sensory organs.</p>
<p>SC.3.L.14.2 Investigate and describe how plants respond to stimuli (heat, light, gravity), such as the way plant stems grow toward light and their roots grow downward in response to gravity.</p>		<p>SC.5.L.14.2 Compare and contrast the function of organs and other physical structures of plants and animals, including humans, for example: some animals have skeletons for support — some with internal skeletons others with exoskeletons — while some plants have stems for support.</p>

GRADES 3–5 FCAT 2.0 SCIENCE BENCHMARKS

Big Idea 15 Diversity and Evolution of Living Organisms		
Grade 3	Grade 4	Grade 5
<p>SC.3.L.15.1 Classify animals into major groups (mammals, birds, reptiles, amphibians, fish, arthropods, vertebrates and invertebrates, those having live births and those which lay eggs) according to their physical characteristics and behaviors.</p>		<p>SC.5.L.15.1 Describe how, when the environment changes, differences between individuals allow some plants and animals to survive and reproduce while others die or move to new locations.</p>
<p>SC.3.L.15.2 Classify flowering and nonflowering plants into major groups such as those that produce seeds, or those like ferns and mosses that produce spores, according to their physical characteristics.</p>		
Big Idea 16 Heredity and Reproduction		
Grade 3	Grade 4	Grade 5
	<p>SC.4.L.16.1 Identify processes of sexual reproduction in flowering plants, including pollination, fertilization (seed production), seed dispersal, and germination.</p>	
	<p>SC.4.L.16.2 Explain that although characteristics of plants and animals are inherited, some characteristics can be affected by the environment.</p>	
	<p>SC.4.L.16.3 Recognize that animal behaviors may be shaped by heredity and learning.</p>	

GRADES 3–5 FCAT 2.0 SCIENCE BENCHMARKS

Big Idea 16 Heredity and Reproduction		
Grade 3	Grade 4	Grade 5
	<p>SC.4.L.16.4 Compare and contrast the major stages in the life cycles of Florida plants and animals, such as those that undergo incomplete and complete metamorphosis, and flowering and nonflowering seed-bearing plants.</p>	
Big Idea 17 Interdependence		
Grade 3	Grade 4	Grade 5
<p>SC.3.L.17.1 Describe how animals and plants respond to changing seasons.</p>	<p>SC.4.L.17.1 Compare the seasonal changes in Florida plants and animals to those in other regions of the country.</p>	<p>SC.5.L.17.1 Compare and contrast adaptations displayed by animals and plants that enable them to survive in different environments such as life cycles variations, animal behaviors and physical characteristics.</p>
<p>SC.3.L.17.2 Recognize that plants use energy from the Sun, air, and water to make their own food.</p>	<p>SC.4.L.17.2 Explain that animals, including humans, cannot make their own food and that when animals eat plants or other animals, the energy stored in the food source is passed to them.</p>	
	<p>SC.4.L.17.3 Trace the flow of energy from the Sun as it is transferred along the food chain through the producers to the consumers.</p>	
	<p>SC.4.L.17.4 Recognize ways plants and animals, including humans, can impact the environment.</p>	
Big Idea 18 Matter and Energy Transformations		
Grade 3	Grade 4	Grade 5

INDIVIDUAL BENCHMARK SPECIFICATIONS FOR FCAT 2.0 SCIENCE GRADE 8

This section of the *Specifications* describes how the science benchmarks are assessed on the FCAT 2.0. Each grade level includes benchmarks from the four Bodies of Knowledge (Nature of Science, Life Science, Earth Science, and Physical Science). Eighteen Big Ideas thread throughout all the grade levels and build in rigor and depth as students advance.

The sample test items included in the *Specifications* represent, whenever possible, a range of difficulty and cognitive complexity. Although most of the test items are of a average difficulty and moderate complexity, some of the test items presented will be challenging for some students and are specifically included to prompt item writers to submit test items that will measure the abilities of higher-achieving students. As a general rule, test items should be written at the cognitive level of the benchmark.

BENCHMARK SC.8.N.1.1

Reporting Category	The Nature of Science
Standard	Big Idea 1 The Practice of Science
Benchmark	SC.8.N.1.1 Define a problem from the eighth grade curriculum using appropriate reference materials to support scientific understanding, plan and carry out scientific investigations of various types, such as systematic observations or experiments, identify variables, collect and organize data, interpret data in charts, tables, and graphics, analyze information, make predictions, and defend conclusions. (Also assesses SC.6.N.1.1, SC.6.N.1.3, SC.7.N.1.1, SC.7.N.1.3, SC.7.N.1.4, SC.8.N.1.3, and SC.8.N.1.4.)
Also Assesses	<p>SC.6.N.1.1 Define a problem from the sixth grade curriculum, use appropriate reference materials to support scientific understanding, plan and carry out scientific investigation of various types, such as systematic observations or experiments, identify variables, collect and organize data, interpret data in charts, tables, and graphics, analyze information, make predictions, and defend conclusions.</p> <p>SC.6.N.1.3 Explain the difference between an experiment and other types of scientific investigation, and explain the relative benefits and limitations of each.</p> <p>SC.7.N.1.1 Define a problem from the seventh grade curriculum, use appropriate reference materials to support scientific understanding, plan and carry out scientific investigation of various types, such as systematic observations or experiments, identify variables, collect and organize data, interpret data in charts, tables, and graphics, analyze information, make predictions, and defend conclusions.</p> <p>SC.7.N.1.3 Distinguish between an experiment (which must involve the identification and control of variables) and other forms of scientific investigation and explain that not all scientific knowledge is derived from experimentation.</p> <p>SC.7.N.1.4 Identify test variables (independent variables) and outcome variables (dependent variables) in an experiment.</p> <p>SC.8.N.1.3 Use phrases such as “results support” or “fail to support” in science, understanding that science does not offer conclusive ‘proof’ of a knowledge claim.</p> <p>SC.8.N.1.4 Explain how hypotheses are valuable if they lead to further investigations, even if they turn out not to be supported by the data.</p>

Benchmark Clarifications	<p>Students will evaluate a scientific investigation using evidence of scientific thinking and/or problem solving.</p> <p>Students will identify test variables (independent variables) and/or outcome variables (dependent variables) in a given scientific investigation.</p> <p>Students will interpret and/or analyze data to make predictions and/or defend conclusions.</p> <p>Students will distinguish between an experiment and other types of scientific investigations where variables cannot be controlled.</p> <p>Students will explain how hypotheses are valuable.</p>
Content Limits	<p>Items addressing hypotheses will not assess whether the hypothesis is supported by data.</p> <p>Items will not address or assess replication, repetition, or the difference between replication and repetition.</p> <p>Items will not assess the reason for differences in data across groups that are investigating the same problem.</p>
Stimulus Attributes	<p>Scenarios in items will be limited to those familiar to a middle-school student rather than global situations.</p> <p>The term <i>test variable</i> should be followed by (<i>independent variable</i>) and the term <i>outcome variable</i> should be followed by (<i>dependent variable</i>).</p>
Response Attribute	<p>The term <i>test variable</i> should be followed by (<i>independent variable</i>) and the term <i>outcome variable</i> should be followed by (<i>dependent variable</i>).</p>
Prior Knowledge	<p>Items may require the student to apply science knowledge described in the NGSSS from lower grades. This benchmark requires prerequisite knowledge from SC.3.N.1.1, SC.3.N.1.3, SC.4.N.1.1, SC.4.N.1.6, SC.5.N.1.1, SC.5.N.1.2, SC.5.N.1.4, and SC.5.N.1.5.</p>

Sample Item 1 **SC.7.N.1.4**

Keesha did an experiment to study the rate of photosynthesis in the water plant *Elodea*. She placed a piece of *Elodea* in a beaker of water and set the beaker 10 centimeters (cm) from a light source. Keesha counted the bubbles released from the plant every minute for five minutes (min). She repeated the process two more times. First, she moved the light to 20 cm from the beaker, and then she moved the light to 30 cm from the beaker. Keesha's setup and data are shown below.

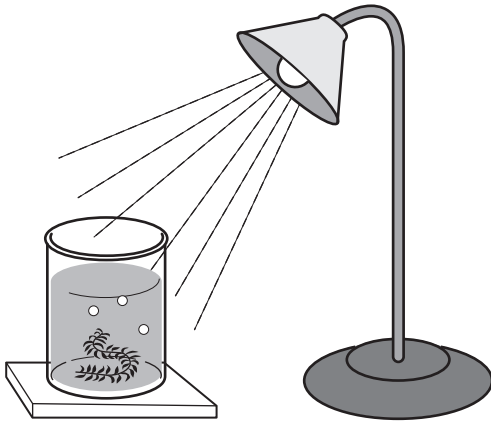

Number of Bubbles			
Time (min)	Distance (cm)		
	10	20	30
1	30	5	1
2	29	5	1
3	31	6	3
4	31	4	2
5	30	4	2

What is the outcome variable (dependent variable) in this experiment?

- ★ A. the number of bubbles produced
- B. the type of plant placed in the beaker
- C. the distance of the light source from the plant
- D. the amount of time the bubbles were counted

BENCHMARK SC.7.N.1.2

Reporting Category	The Nature of Science
Standard	Big Idea 1 The Practice of Science
Benchmark	SC.7.N.1.2 Differentiate replication (by others) from repetition (multiple trials). (Also assesses SC.6.N.1.2, SC.6.N.1.4, and SC.8.N.1.2.)
Also Assesses	<p>SC.6.N.1.2 Explain why scientific investigations should be replicable.</p> <p>SC.6.N.1.4 Discuss, compare, and negotiate methods used, results obtained, and explanations among groups of students conducting the same investigation.</p> <p>SC.8.N.1.2 Design and conduct a study using repeated trials and replication.</p>
Benchmark Clarifications	<p>Students will differentiate between replication and repetition.</p> <p>Students will explain why scientific investigations should be replicable.</p> <p>Students will compare methods and/or results obtained in a scientific investigation.</p> <p>Students will evaluate the use of repeated trials or replication in a scientific investigation.</p>
Content Limits	None specified
Stimulus Attributes	None specified
Response Attributes	None specified
Prior Knowledge	Items may require the student to apply science knowledge described in the NGSSS from lower grades. This benchmark requires prerequisite knowledge from SC.3.N.1.2, SC.3.N.1.5, SC.4.N.1.2, SC.4.N.1.5, SC.5.N.1.3, and SC.5.N.2.2.

Sample Item 2 **SC.7.N.1.2**

The following statements were taken from the procedures of four different investigations.

Investigation	Statement
1	Pour 50 milliliters (mL) of water down four inclined surfaces.
2	Roll a marble down the ramp from a height of 10 centimeters (cm), 20 cm, and 30 cm.
3	Take the mass of five rocks separately and then determine the average mass in grams (g).
4	Conduct four trials of counting the bubbles produced by a water plant for 1 minute (min) each.

The statement from which investigation is an example of repetition?

- A. Investigation 1
- B. Investigation 2
- C. Investigation 3
- ★ D. Investigation 4

BENCHMARK SC.7.N.1.5

Reporting Category	The Nature of Science
Standard	Big Idea 1 The Practice of Science
Benchmark	SC.7.N.1.5 Describe the methods used in the pursuit of a scientific explanation as seen in different fields of science such as biology, geology, and physics. (Also assesses SC.7.N.3.2, SC.8.N.1.5, and SC.8.E.5.10.)
Also Assesses	<p>SC.7.N.3.2 Identify the benefits and limitations of the use of scientific models.</p> <p>SC.8.N.1.5 Analyze the methods used to develop a scientific explanation as seen in different fields of science.</p> <p>SC.8.E.5.10 Assess how technology is essential to science for such purposes as access to outer space and other remote locations, sample collection, measurement, data collection and storage, computation, and communication of information.</p>
Benchmark Clarifications	<p>Students will describe and/or analyze common methods and/or models used in different fields of study.</p> <p>Students will identify the benefits and/or limitations of the use of scientific models.</p> <p>Students will identify how technology is essential to science.</p>
Content Limit	Items assessing technology will focus on the role of technology in science as opposed to specific technologies.
Stimulus Attributes	None specified
Response Attributes	None specified
Prior Knowledge	Items may require the student to apply science knowledge described in the NGSSS from lower grades. This benchmark requires prerequisite knowledge from SC.3.N.3.2, SC.3.N.3.3, SC.4.N.3.1, and SC.6.N.3.4.

Sample Item 3

SC.7.N.3.2

Two types of models that can be used to show details of the structures of cells are shown below.

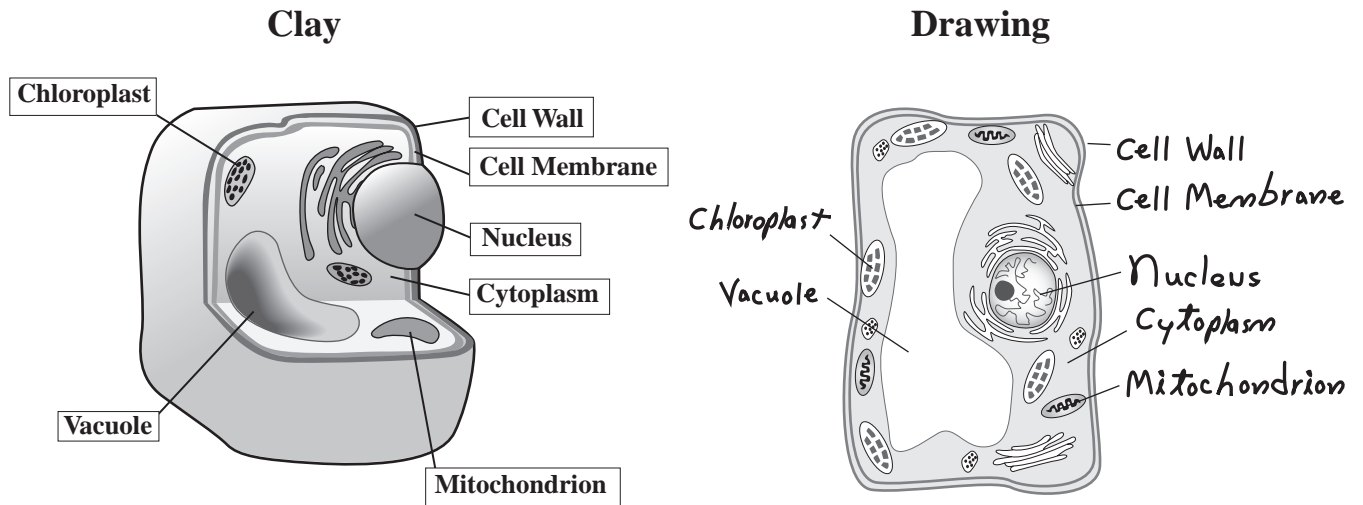

Which of the following describes a limitation of the drawing but NOT the clay model?

- A. It does not represent the main parts of a cell.
- B. It does not contain the correct number of nuclei.
- ★ C. It cannot represent a living cell, since a true cell is three-dimensional.
- D. It cannot represent a living cell, since the cytoplasm should be in constant motion.

BENCHMARK SC.6.N.2.2

Reporting Category	The Nature of Science
Standard	Big Idea 2 The Characteristics of Scientific Knowledge
Benchmark	SC.6.N.2.2 Explain that scientific knowledge is durable because it is open to change as new evidence or interpretations are encountered. (Also assesses SC.7.N.1.6, SC.7.N.1.7, SC.7.N.2.1, and SC.8.N.1.6.)
Also Assesses	<p>SC.7.N.1.6 Explain that empirical evidence is the cumulative body of observations of a natural phenomenon on which scientific explanations are based.</p> <p>SC.7.N.1.7 Explain that scientific knowledge is the result of a great deal of debate and confirmation within the science community.</p> <p>SC.7.N.2.1 Identify an instance from the history of science in which scientific knowledge has changed when new evidence or new interpretations are encountered.</p> <p>SC.8.N.1.6 Understand that scientific investigations involve the collection of relevant empirical evidence, the use of logical reasoning, and the application of imagination in devising hypotheses, predictions, explanations and models to make sense of the collected evidence.</p>
Benchmark Clarifications	<p>Students will explain that scientific knowledge may change as new evidence is discovered or new scientific interpretations are formed.</p> <p>Students will explain that scientific explanations are based on empirical evidence, logical reasoning, predictions, and modeling.</p> <p>Students will identify instances in the history of science in which scientific knowledge has changed as a result of new evidence.</p>
Content Limits	<p>Items will not require identification of the scientist(s) and/or details associated with a particular event/discovery.</p> <p>Items will not use the term <i>durable</i>.</p>
Stimulus Attributes	<p>Scenarios referring to empirical evidence will use the term <i>evidence</i>.</p> <p>The phrase <i>natural event</i> should be used rather than <i>natural phenomenon</i>.</p>
Response Attributes	None specified
Prior Knowledge	Items may require the student to apply science knowledge described in the NGSSS from lower grades. This benchmark requires prerequisite knowledge from SC.3.N.1.7, SC.4.N.1.3, SC.4.N.1.7, SC.5.N.1.5, SC.5.N.1.6, and SC.5.N.2.1.

Sample Item 4 **SC.6.N.2.2**

Scientific knowledge may change as new evidence or information is discovered. Which of the following would NOT be a result of new scientific research and information?

- A. Binomial nomenclature is assigned to a recently identified plant species.
- B. An endangered monkey species is put in a reserve for protection from extinction.
- C. A newly discovered chemical element will be added to the periodic table of the elements.
- ★ D. A nonnative plant species will begin to reproduce rapidly after being introduced into a swamp ecosystem.

BENCHMARK SC.7.N.3.1

Reporting Category	The Nature of Science
Standard	Big Idea 3 The Role of Theories, Laws, Hypotheses, and Models
Benchmark	SC.7.N.3.1 Recognize and explain the difference between theories and laws and give several examples of scientific theories and the evidence that supports them. (Also assesses SC.6.N.3.1 and SC.8.N.3.2.)
Also Assesses	<p>SC.6.N.3.1 Recognize and explain that a scientific theory is a well-supported and widely accepted explanation of nature and is not simply a claim posed by an individual. Thus, the use of the term theory in science is very different than how it is used in everyday life.</p> <p>SC.8.N.3.2 Explain why theories may be modified but are rarely discarded.</p>
Benchmark Clarifications	<p>Students will explain the difference between theories and laws.</p> <p>Students will identify examples of theories and/or laws.</p> <p>Students will explain why theories may be modified but are rarely discarded.</p>
Content Limit	Items addressing scientific theories and/or laws are limited to those found in the middle school science benchmarks, such as law of universal gravitation, law of superposition, theory of plate tectonics, atomic theory, law of conservation of mass, law of conservation of energy, cell theory, and the scientific theory of evolution.
Stimulus Attributes	None specified
Response Attributes	None specified
Prior Knowledge	Items may require the student to apply science knowledge described in the NGSSS from lower grades. This benchmark requires prerequisite knowledge from SC.6.N.3.2 and SC.6.N.3.3.

Sample Item 5 **SC.8.N.3.2**

A timeline of some models of atoms throughout history is shown below. These models have contributed to the formation of the atomic theory.

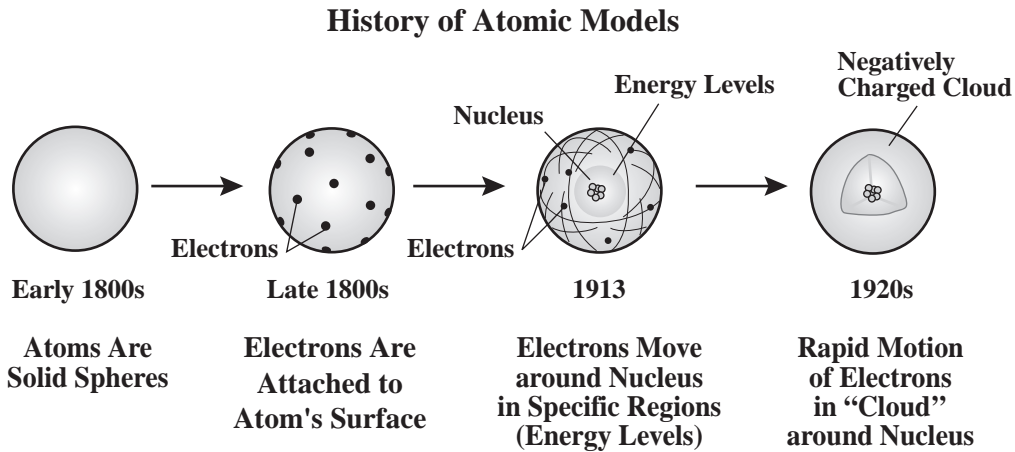

Which statement **best** summarizes the development of the atomic theory over time?

- A. Advancements in atomic models proved the atomic theory was accurate.
- ★ B. The discovery of new evidence resulted in changes to the atomic theory.
- C. With the discovery of every new element, the atomic theory was modified.
- D. Changes in atomic models showed that the atomic theory was based on opinion.

BENCHMARK SC.8.E.5.3

Reporting Category	Earth and Space Science
Standard	Big Idea 5 Earth in Space and Time
Benchmark	SC.8.E.5.3 Distinguish the hierarchical relationships between planets and other astronomical bodies relative to solar system, galaxy, and universe, including distance, size, and composition. (Also assesses SC.8.E.5.1 and SC.8.E.5.2.)
Also Assesses	<p>SC.8.E.5.1 Recognize that there are enormous distances between objects in space and apply our knowledge of light and space travel to understand this distance.</p> <p>SC.8.E.5.2 Recognize that the universe contains many billions of galaxies and that each galaxy contains many billions of stars.</p>
Benchmark Clarifications	<p>Students will compare and/or contrast the relative distance, relative size, and general composition of astronomical bodies in the universe.</p> <p>Students will describe distances between objects in space in the context of light and space travel.</p> <p>Students will describe that the universe contains billions of galaxies and stars.</p>
Content Limits	<p>Items assessing astronomical bodies are limited to planets, stars, moons, asteroids, nebulae, galaxies, dwarf planets, and comets.</p> <p>Items will not assess the order of the planets from the Sun in our solar system in isolation.</p> <p>Items will not require memorization of quantitative astronomical data.</p> <p>Items will not assess the specific chemical composition of astronomical bodies.</p> <p>Items will not require calculations but may require comparison or use of quantitative data, including tables.</p>
Stimulus Attribute	Distances will be given in units of astronomical units (AU) or light-years.
Response Attribute	Distances will be given in units of astronomical units (AU) or light-years.
Prior Knowledge	Items may require the student to apply science knowledge described in the NGSSS from lower grades. This benchmark requires prerequisite knowledge from SC.5.E.5.1, SC.5.E.5.2, and SC.5.E.5.3.

Sample Item 6 **SC.8.E.5.3**

The points labeled on the chart below represent the approximate size of Earth, the Milky Way, the Moon, and the Sun. The approximate size of the solar system is also shown.

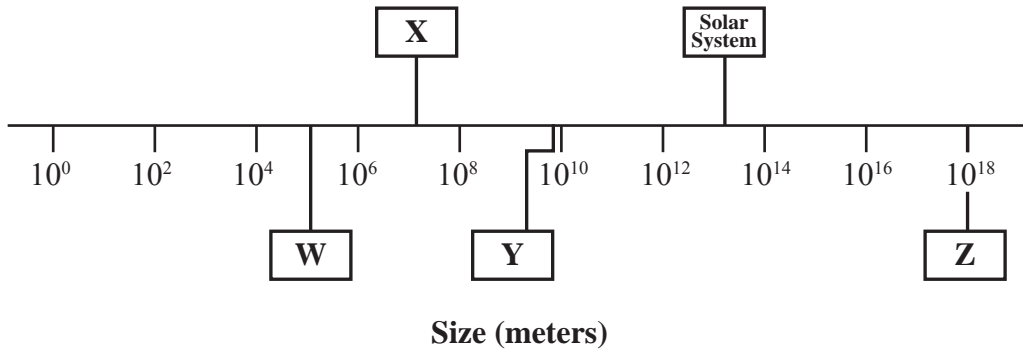

Which point on the chart **best** represents the approximate size of the Sun?

- A. W
- B. X
- ★ C. Y
- D. Z

BENCHMARK SC.8.E.5.5

Reporting Category	Earth and Space Science
Standard	Big Idea 5 Earth in Space and Time
Benchmark	SC.8.E.5.5 Describe and classify specific physical properties of stars: apparent magnitude (brightness), temperature (color), size, and luminosity (absolute brightness). (Also assesses SC.8.E.5.6.)
Also Assesses	SC.8.E.5.6 Create models of solar properties including: rotation, structure of the Sun, convection, sunspots, solar flares, and prominences.
Benchmark Clarifications	<p>Students will describe and/or classify physical properties of stars: apparent magnitude, temperature (color), size, and absolute brightness.</p> <p>Students will evaluate models of solar properties and/or explain solar characteristics, including rotation, structure of the Sun, convection, sunspots, solar flares, and prominences.</p>
Content Limits	<p>Items addressing stars will focus on main sequence stars and their properties.</p> <p>Items will not assess stages of stellar evolution.</p> <p>Items will not assess the specific chemical composition of stars.</p>
Stimulus Attributes	<p>Distances will be given in units of astronomical units (AU) or light-years.</p> <p>The phrase <i>absolute brightness</i> should be used rather than <i>luminosity</i>.</p>
Response Attribute	Distances will be given in units of astronomical units (AU) or light-years.
Prior Knowledge	Items may require the student to apply science knowledge described in the NGSSS from lower grades. This benchmark requires prerequisite knowledge from SC.3.E.5.1, SC.3.E.5.2, SC.3.E.5.3, and SC.5.E.5.1.

Sample Item 7 **SC.8.E.5.5**

One physical property of a star is apparent magnitude. Which of the following is used in determining the apparent magnitude of a star?

- A. the constellation the star is in
- ★ B. the distance the star is from Earth
- C. the number of times the star rotates
- D. the number of prominences the star makes

BENCHMARK SC.8.E.5.7

Reporting Category	Earth and Space Science
Standard	Big Idea 5 Earth in Space and Time
Benchmark	SC.8.E.5.7 Compare and contrast the properties of objects in the Solar System including the Sun, planets, and moons to those of Earth, such as gravitational force, distance from the Sun, speed, movement, temperature, and atmospheric conditions. (Also assesses SC.8.E.5.4 and SC.8.E.5.8.)
Also Assesses	<p>SC.8.E.5.4 Explore the Law of Universal Gravitation by explaining the role that gravity plays in the formation of planets, stars, and solar systems and in determining their motions.</p> <p>SC.8.E.5.8 Compare various historical models of the Solar System, including geocentric and heliocentric.</p>
Benchmark Clarifications	<p>Students will compare and/or contrast the characteristics of objects in the Solar System.</p> <p>Students will identify and/or explain the role that gravity plays in the formation and motion of planets, stars, and solar systems.</p> <p>Students will compare and/or contrast various historical models of the Solar System.</p>
Content Limits	<p>Items will not require the use of the formula for the Law of Universal Gravitation or the gravitational constant.</p> <p>Items may assess the presence, absence, and/or relative thickness of planetary atmospheres, but not the chemical composition of the atmosphere.</p> <p>Items may assess the relationship between distance from the Sun and the length of year and/or the relationship between distance from the Sun and average surface temperature.</p> <p>Items will not require memorization of quantitative astronomical data.</p> <p>Items may refer to but will not assess the relative size of the Sun.</p> <p>Items will not assess the relative distance of objects in our solar system from the Sun.</p> <p>Items will not assess the change in velocity dependent upon distance from the Sun for a single planet.</p>

Content Limits	<p>Items will not assess characteristics of the Sun in isolation.</p> <p>Items may assess the concept of eccentricity of orbital paths of astronomical bodies in terms of the differing shapes of orbits, but not specific values of eccentricity or the term eccentricity.</p> <p>Items may assess the general properties of specific planets, but will not assess characteristics of inner and outer planets as groups.</p>
Stimulus Attribute	Distances will be given in units of astronomical units (AU) or light-years.
Response Attribute	Distances will be given in units of astronomical units (AU) or light-years.
Prior Knowledge	Items may require the student to apply science knowledge described in the NGSSS from lower grades. This benchmark requires prerequisite knowledge from SC.3.E.5.4, SC.5.E.5.2, and SC.5.E.5.3.

Sample Item 8 **SC.8.E.5.7**

The surface of Mercury has many more craters than the surface of Earth has. Which of the following statements **best** explains why Mercury has many more craters than Earth has?

- A. Mercury rotates faster than Earth does.
- B. Mercury has a smaller mass than Earth has.
- C. Mercury is much closer to the Sun than Earth is.
- ★ D. Mercury has a thinner atmosphere than Earth has.

BENCHMARK SC.8.E.5.9

Reporting Category	Earth and Space Science
Standard	Big Idea 5 Earth in Space and Time
Benchmark	SC.8.E.5.9 Explain the impact of objects in space on each other including: 1. the Sun on the Earth including seasons and gravitational attraction 2. the Moon on the Earth, including phases, tides, and eclipses, and the relative position of each body.
Benchmark Clarification	Students will explain the effect of astronomical bodies on each other including the Sun's and/or the Moon's effects on Earth.
Content Limit	Items addressing eclipses should be assessed at the conceptual level and will not assess specific vocabulary associated with eclipses, such as <i>umbra</i> and <i>penumbra</i> .
Stimulus Attributes	None specified
Response Attribute	Options may be in the form of labeled illustrations.
Prior Knowledge	Items may require the student to apply science knowledge described in the NGSSS from lower grades. This benchmark requires prerequisite knowledge from SC.4.E.5.1, SC.4.E.5.2, SC.4.E.5.3, and SC.4.E.5.4.

Sample Item 9 SC.8.E.5.9

The water level at the beach changes during the day. What causes the different water levels?

- A. Earth's revolution
- B. the Moon's rotation
- C. Earth's magnetic field
- ★ D. the Moon's gravitational pull

BENCHMARK SC.7.E.6.2

Reporting Category	Earth and Space Science
Standard	Big Idea 6 Earth Structures
Benchmark	SC.7.E.6.2 Identify the patterns within the rock cycle and relate them to surface events (weathering and erosion) and sub-surface events (plate tectonics and mountain building). (Also assesses SC.6.E.6.1, SC.6.E.6.2, and SC.7.E.6.6.)
Also Assesses	<p>SC.6.E.6.1 Describe and give examples of ways in which Earth’s surface is built up and torn down by physical and chemical weathering, erosion, and deposition.</p> <p>SC.6.E.6.2 Recognize that there are a variety of different landforms on Earth’s surface such as coastlines, dunes, rivers, mountains, glaciers, deltas, and lakes and relate these landforms as they apply to Florida.</p> <p>SC.7.E.6.6 Identify the impact that humans have had on Earth, such as deforestation, urbanization, desertification, erosion, air and water quality, changing the flow of water.</p>
Benchmark Clarifications	<p>Students will identify and/or describe steps of the rock cycle and relate them to surface and sub-surface events.</p> <p>Students will describe and/or explain how Earth’s surface is built up and torn down through the processes of physical and chemical weathering, erosion, and deposition.</p> <p>Students will identify different types of landforms commonly found on Earth.</p> <p>Students will describe similarities and/or differences among landforms found in Florida and those found outside of Florida.</p> <p>Students will identify and/or describe the impact that humans have had on Earth.</p>
Content Limits	<p>Items may use the context of plate tectonics to assess the rock cycle but will not directly assess plate tectonics.</p> <p>Items will not assess the role of plate tectonics in landform formation.</p> <p>Items may assess the features of karst topography, such as aquifers, caverns, and/or sinkholes, but will not use the term <i>karst topography</i>.</p>

Stimulus Attributes	None specified
Response Attributes	None specified
Prior Knowledge	Items may require the student to apply science knowledge described in the NGSSS from lower grades. This benchmark requires prerequisite knowledge from SC.4.E.6.1, SC.4.E.6.2, SC.4.E.6.3, SC.4.E.6.4, and SC.4.E.6.6.

Sample Item 10 **SC.7.E.6.6**

Deforestation occurs when large areas of trees are cut down. Which of the following impacts on the environment would result from deforestation?

- ★ A. increased erosion
- B. colder temperatures
- C. excess ground moisture
- D. greater oxygen production

BENCHMARK SC.7.E.6.4

Reporting Category	Earth and Space Science
Standard	Big Idea 6 Earth Structures
Benchmark	SC.7.E.6.4 Explain and give examples of how physical evidence supports scientific theories that Earth has evolved over geologic time due to natural processes. (Also assesses SC.7.E.6.3.)
Also Assesses	SC.7.E.6.3 Identify current methods for measuring the age of Earth and its parts, including the law of superposition and radioactive dating.
Benchmark Clarifications	<p>Students will identify examples of and/or explain physical evidence that supports scientific theories that Earth has evolved over geologic time due to natural processes.</p> <p>Students will identify and/or describe current scientific methods for measuring the age of Earth and its parts.</p>
Content Limits	<p>Items may address fossil records but should not require knowledge or recognition of specific organisms.</p> <p>Items may address folding and faulting as related to the law of superposition.</p> <p>Items assessing radioactive dating will be limited to a conceptual level. Items will not require calculations or address half-life.</p> <p>Items addressing geologic time will not require specific knowledge of eras, periods, or epochs.</p>
Stimulus Attributes	None specified
Response Attributes	None specified
Prior Knowledge	This benchmark grouping is foundational. These concepts have not been introduced in the NGSSS prior to this grade-level grouping.

Sample Item 11 **SC.7.E.6.3**

The oldest rock formation identified on Earth is found on the shoreline of Hudson Bay in Canada. This rock formed 4.28 billion years ago. What information does a scientist need to more accurately determine the age of a rock?

- A. the percentage of each mineral that makes up the rock
- B. the thickness of younger rock layers that cover the rock
- ★ C. the amount of each radioactive element present in the rock
- D. the amount of weathering present on the surface of the rock

BENCHMARK SC.7.E.6.5

Reporting Category	Earth and Space Science
Standard	Big Idea 6 Earth Structures
Benchmark	SC.7.E.6.5 Explore the scientific theory of plate tectonics by describing how the movement of Earth’s crustal plates causes both slow and rapid changes in Earth’s surface, including volcanic eruptions, earthquakes, and mountain building. (Also assesses SC.7.E.6.1 and SC.7.E.6.7.)
Also Assesses	<p>SC.7.E.6.1 Describe the layers of the solid Earth, including the lithosphere, the hot convecting mantle, and the dense metallic liquid and solid cores.</p> <p>SC.7.E.6.7 Recognize that heat flow and movement of material within Earth causes earthquakes and volcanic eruptions, and creates mountains and ocean basins.</p>
Benchmark Clarifications	<p>Students will describe the scientific theory of plate tectonics and/or how the movement of Earth’s crustal plates and the flow of heat and material cause various geologic events to occur.</p> <p>Students will identify and/or describe the layers of Earth.</p>
Content Limits	<p>Items will not assess types of volcanoes but may assess different causes of volcano formation.</p> <p>Items will not assess types of earthquake waves.</p> <p>Items may assess density differences between layers of Earth but will not assess density differences as they relate to plate tectonics.</p> <p>Items assessing the layers of Earth are limited to the crust, the lithosphere, the hot convecting mantle, the outer (liquid) core, and the inner (solid) core.</p>
Stimulus Attributes	None specified
Response Attributes	None specified
Prior Knowledge	This benchmark grouping is foundational. These concepts have not been introduced in the NGSSS prior to this grade-level grouping.

Sample Item 12**SC.7.E.6.1**

Interactions between layers of Earth cause convection currents to move crustal plates. The diagram below shows four layers of Earth.

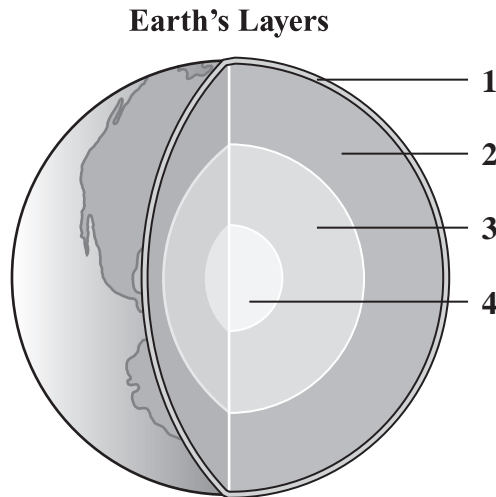

In which layer of Earth are the convection currents that directly result in tectonic plate motion found?

- A. 1
- ★ B. 2
- C. 3
- D. 4

BENCHMARK SC.6.E.7.4

Reporting Category	Earth and Space Science
Standard	Big Idea 7 Earth Systems and Patterns
Benchmark	SC.6.E.7.4 Differentiate and show interactions among the geosphere, hydrosphere, cryosphere, atmosphere, and biosphere. (Also assesses SC.6.E.7.2, SC.6.E.7.3, SC.6.E.7.6, and SC.6.E.7.9.)
Also Assesses	<p>SC.6.E.7.2 Investigate and apply how the cycling of water between the atmosphere and hydrosphere has an effect on weather patterns and climate.</p> <p>SC.6.E.7.3 Describe how global patterns such as the jet stream and ocean currents influence local weather in measurable terms such as temperature, air pressure, wind direction and speed, and humidity and precipitation.</p> <p>SC.6.E.7.6 Differentiate between weather and climate.</p> <p>SC.6.E.7.9 Describe how the composition and structure of the atmosphere protects life and insulates the planet.</p>
Benchmark Clarifications	<p>Students will differentiate and/or explain interactions among the geosphere, hydrosphere, cryosphere, atmosphere, and biosphere.</p> <p>Students will describe and/or explain how the cycling of water and global patterns influence local weather and climate.</p> <p>Students will differentiate between weather and climate.</p> <p>Students will describe the composition and structure of the atmosphere and/or how the atmosphere protects life and insulates the planet.</p>
Content Limits	<p>Items will not assess atmospheres of planets other than Earth.</p> <p>Items may assess atmospheric conditions and their resulting weather phenomena, such as hurricanes, tornadoes, lightning, fronts, and precipitation.</p> <p>Items will not address auroras.</p> <p>Items will not assess the causes of global warming or the ozone hole but may assess their effects.</p> <p>Items may assess the layers of the atmosphere and/or the function of each.</p> <p>Items should not assess the water cycle in isolation.</p>

Stimulus Attributes	Items assessing the jet stream, the Gulf Stream, or other winds and/or currents must include a map showing these patterns. Temperature should be shown in degrees Celsius followed by the equivalent degrees Fahrenheit temperature in parentheses.
Response Attribute	Temperature should be shown in degrees Celsius followed by the equivalent degrees Fahrenheit temperature in parentheses.
Prior Knowledge	Items may require the student to apply science knowledge described in the NGSSS from lower grades. This benchmark requires prerequisite knowledge from SC.5.E.7.1, SC.5.E.7.2, SC.5.E.7.3, SC.5.E.7.4, SC.5.E.7.5, and SC.5.E.7.6.

Sample Item 13 **SC.6.E.7.6**

The climate of an area can be different from its weather. Which of the following statements describes the climate of an area?

- A. There should be heavy rains tomorrow morning.
- B. The rains next week are expected to cause some flooding.
- ★ C. The average temperature from 1930–1996 was 23°C (74°F).
- D. The high temperature on September 4, 2009, was 32°C (89°F).

BENCHMARK SC.6.E.7.5

Reporting Category	Earth and Space Science
Standard	Big Idea 7 Earth Systems and Patterns
Benchmark	SC.6.E.7.5 Explain how energy provided by the sun influences global patterns of atmospheric movement and the temperature differences between air, water, and land. (Also assesses SC.6.E.7.1.)
Also Assesses	SC.6.E.7.1 Differentiate among radiation, conduction, and convection, the three mechanisms by which heat is transferred through Earth’s system.
Benchmark Clarifications	<p>Students will explain how energy provided by the Sun influences global patterns of atmospheric movement and/or the temperature differences among air, water, and land.</p> <p>Students will differentiate among radiation, conduction, and convection in Earth’s systems.</p>
Content Limits	<p>Items may assess causes of wind and wind patterns but will not assess knowledge of the Coriolis effect.</p> <p>Items assessing radiation, conduction, and/or convection should be in the context of the atmosphere, geosphere, and hydrosphere on Earth.</p>
Stimulus Attribute	Temperature should be shown in degrees Celsius, followed by the equivalent degrees Fahrenheit temperature in parentheses.
Response Attribute	Temperature should be shown in degrees Celsius, followed by the equivalent degrees Fahrenheit temperature in parentheses.
Prior Knowledge	Items may require the student to apply science knowledge described in the NGSSS from lower grades. This benchmark requires prerequisite knowledge from SC.3.E.6.1.

Sample Item 14

SC.6.E.7.1

The arrows in the picture below show several ways heat is transferred from the Sun as it strikes sand on the surface of a beach.

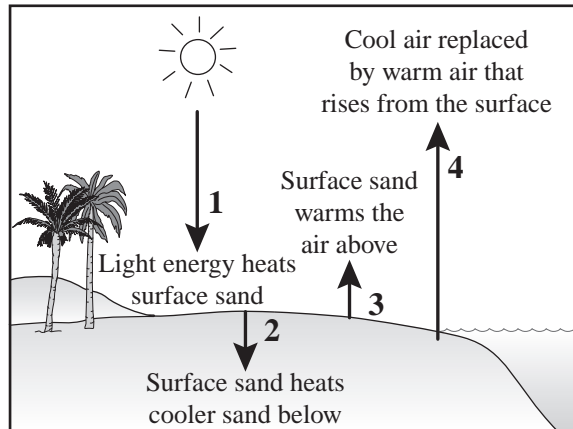

Which arrow shows convection?

- A. 1
- B. 2
- C. 3
- ★ D. 4

BENCHMARK SC.8.P.8.4

Reporting Category	Physical Science
Standard	Big Idea 8 Properties of Matter
Benchmark	SC.8.P.8.4 Classify and compare substances on the basis of characteristic physical properties that can be demonstrated or measured; for example, density, thermal or electrical conductivity, solubility, magnetic properties, melting and boiling points, and know that these properties are independent of the amount of the sample. (Also assesses SC.8.P.8.3.)
Also Assesses	SC.8.P.8.3 Explore and describe the densities of various materials through measurement of their masses and volumes.
Benchmark Clarifications	<p>Students will classify and/or compare substances on the basis of their physical properties and/or explain that these properties are independent of the amount of the sample.</p> <p>Students will describe density and/or calculate and compare the densities of various materials using the materials' masses and volumes.</p>
Content Limits	<p>Items may require use of the density formula to calculate density, mass, or volume when comparing substances.</p> <p>Items that assess conductivity, solubility, or magnetic properties will be at a conceptual level only. Items will not require calculations for these topics.</p> <p>Items addressing solubility may include the terms <i>solvent</i>, <i>solute</i>, and <i>saturation</i>. Items may assess the concept of saturation.</p> <p>Items will not require memorization of the specific melting points and/or boiling points of substances.</p>
Stimulus Attributes	<p>Temperature will only be shown in degrees Celsius (°C).</p> <p>Scenarios requiring calculation of density must include the density equation.</p>
Response Attributes	None specified
Prior Knowledge	Items may require the student to apply science knowledge described in the NGSSS from lower grades. This benchmark requires prerequisite knowledge from SC.3.P.8.1, SC.3.P.8.2, SC.3.P.8.3, SC.3.P.9.1, SC.4.P.8.1, SC.P.4.8.2, SC.4.P.8.4, SC.5.P.8.1, SC.5.P.11.1, and SC.5.P.11.2.

Sample Item 15 **SC.8.P.8.4**

Matthew has six cubes of different materials. Each cube has a mass of 10 grams (g). Matthew sorts the cubes into two groups using one physical property.

GROUPS OF DIFFERENT MATERIALS

Group 1 Cubes	Group 2 Cubes
Aluminum	Glass
Copper	Plastic
Steel	Wood

Which physical property did Matthew **most likely** use to sort the cubes into two groups?

- A. density
- B. magnetism
- C. melting point
- ★ D. electrical conductivity

BENCHMARK SC.8.P.8.5

Reporting Category	Physical Science
Standard	Big Idea 8 Properties of Matter
Benchmark	SC.8.P.8.5 Recognize that there are a finite number of elements and that their atoms combine in a multitude of ways to produce compounds that make up all of the living and nonliving things that we encounter. (Also assesses SC.8.P.8.1, SC.8.P.8.6, SC.8.P.8.7, SC.8.P.8.8, and SC.8.P.8.9.)
Also Assesses	<p>SC.8.P.8.1 Explore the scientific theory of atoms (also known as atomic theory) by using models to explain the motion of particles in solids, liquids, and gases.</p> <p>SC.8.P.8.6 Recognize that elements are grouped in the periodic table according to similarities of their properties.</p> <p>SC.8.P.8.7 Explore the scientific theory of atoms (also known as atomic theory) by recognizing that atoms are the smallest unit of an element and are composed of sub-atomic particles (electrons surrounding a nucleus containing protons and neutrons).</p> <p>SC.8.P.8.8 Identify basic examples of and compare and classify the properties of compounds, including acids, bases, and salts.</p> <p>SC.8.P.8.9 Distinguish among mixtures (including solutions) and pure substances.</p>
Benchmark Clarifications	<p>Students will describe how elements combine in a multitude of ways to produce compounds that make up all living and nonliving things.</p> <p>Students will describe the motion of particles in solids, liquids, and/or gases.</p> <p>Students will explain that elements are grouped in the periodic table according to similarities of their properties.</p> <p>Students will explain that atoms are the smallest unit of an element and are composed of subatomic particles.</p> <p>Students will identify common examples of acids, bases, and/or salts.</p> <p>Students will compare, contrast, and/or classify the properties of compounds, including acids and bases.</p> <p>Students will differentiate among pure substances, mixtures, and solutions.</p>

Content Limits	<p>Items referring to elements are limited to the elements 1–57 and 72–89.</p> <p>Items referring to subatomic particles will only assess protons, neutrons, and electrons.</p> <p>Items will not assess chemical bonding.</p> <p>Items may assess a conceptual understanding of the pH scale. Items will not require knowledge of the pH of specific substances.</p> <p>Items addressing the properties of acids and bases are limited to pH.</p> <p>Items assessing mixtures and solutions may include components in different states of matter (e.g., gas dissolved in liquid).</p> <p>Items assessing periodic trends must be at the conceptual level.</p> <p>Items will not assess valence electrons or electron configurations.</p>
Stimulus Attributes	None specified
Response Attributes	None specified
Prior Knowledge	Items may require the student to apply science knowledge described in the NGSSS from lower grades. This benchmark requires prerequisite knowledge from SC.5.P.8.2 and SC.5.P.8.3.

Sample Item 16 **SC.8.P.8.6**

Lithium (Li), Sodium (Na), Potassium (K), Rubidium (Rb), Cesium (Cs), and Francium (Fr) are in the same column in the periodic table. Why are these elements in the same column in the periodic table?

- A. They are the same size.
- B. They react with each other.
- ★ C. They have similar properties.
- D. They have the same number of protons.

BENCHMARK SC.8.P.9.2

Reporting Category	Physical Science
Standard	Big Idea 9 Changes in Matter
Benchmark	SC.8.P.9.2 Differentiate between physical changes and chemical changes. (Also assesses SC.8.P.9.1 and SC.8.P.9.3.)
Also Assesses	<p>SC.8.P.9.1 Explore the Law of Conservation of Mass by demonstrating and concluding that mass is conserved when substances undergo physical and chemical changes.</p> <p>SC.8.P.9.3 Investigate and describe how temperature influences chemical changes.</p>
Benchmark Clarifications	<p>Students will differentiate between physical and chemical changes.</p> <p>Students will explain that mass is conserved when substances undergo physical and chemical changes, according to the Law of Conservation of Mass.</p> <p>Students will describe how temperature influences chemical changes.</p>
Content Limits	<p>Items will not require balancing equations or analysis of chemical formulas.</p> <p>Items will focus on a conceptual understanding of the Law of Conservation of Mass; items will not require mathematical computations.</p> <p>Items will not assess reaction rates.</p>
Stimulus Attribute	Temperature will only be shown in degrees Celsius (°C).
Response Attribute	Temperature will only be shown in degrees Celsius (°C).
Prior Knowledge	Items may require the student to apply science knowledge described in the NGSSS from lower grades. This benchmark requires prerequisite knowledge from SC.4.P.9.1 and SC.5.P.9.1.

Sample Item 17 **SC.8.P.9.2**

When a candle is lit, the wick burns, the wax melts, the candle changes shape, and the air around the candle heats up. Which of the following is an example of a chemical change?

- ★ **A.** the wick burning
- B.** the wax melting
- C.** the candle changing shape
- D.** the air around the candle heating up

BENCHMARK SC.7.P.10.1

Reporting Category	Physical Science
Standard	Big Idea 10 Forms of Energy
Benchmark	SC.7.P.10.1 Illustrate that the sun’s energy arrives as radiation with a wide range of wavelengths, including infrared, visible, and ultraviolet, and that white light is made up of a spectrum of many different colors. (Also assesses SC.8.E.5.11.)
Also Assesses	SC.8.E.5.11 Identify and compare characteristics of the electromagnetic spectrum such as wavelength, frequency, use, and hazards and recognize its application to an understanding of planetary images and satellite photographs.
Benchmark Clarifications	<p>Students will identify, compare and/or contrast the variety of types of radiation present in radiation from the Sun.</p> <p>Students will identify and/or compare characteristics of the electromagnetic spectrum.</p> <p>Students will identify common uses and/or applications of electromagnetic waves.</p>
Content Limits	<p>Items may assess relative order of frequencies and wavelengths in the electromagnetic spectrum but will not require memorization of specific frequencies and wavelengths of electromagnetic radiation.</p> <p>Items will not address hazards of electromagnetic radiation.</p> <p>Items will address only electromagnetic waves and the electromagnetic spectrum.</p> <p>Items will not require calculations.</p>
Stimulus Attributes	None specified
Response Attributes	None specified
Prior Knowledge	This benchmark grouping is foundational. These concepts have not been introduced in the NGSSS prior to this grade-level grouping.

Sample Item 18 **SC.7.P.10.1**

Sunlight is composed of energy that is visible to humans and energy that is not visible to humans. Which statement describes how the visible energy from the Sun is different from the nonvisible energy?

- A. It travels at a different speed.
- B. It travels a different distance.
- ★ C. It has different wavelengths.
- D. It has different amplitudes.

BENCHMARK SC.7.P.10.3

Reporting Category	Physical Science
Standard	Big Idea 10 Forms of Energy
Benchmark	SC.7.P.10.3 Recognize that light waves, sound waves, and other waves move at different speeds in different materials. (Also assesses SC.7.P.10.2.)
Also Assesses	SC.7.P.10.2 Observe and explain that light can be reflected, refracted, and/or absorbed.
Benchmark Clarifications	<p>Students will describe and/or explain that waves move at different speeds through different materials.</p> <p>Students will explain that light waves can be reflected, refracted, and/or absorbed.</p>
Content Limits	<p>Items may assess the general relative order of wave speed in different phases but will not assess the motion of the particles in the substance.</p> <p>Items may assess pitch as related to frequency.</p> <p>Items will not assess color as related to wavelength.</p> <p>Items will not assess electromagnetic waves traveling in a vacuum.</p> <p>Items will not require calculations of wave speed through different materials.</p> <p>Items may address water waves but not in the context of water waves at the beach.</p> <p>Items will not assess the interaction of multiple waves.</p>
Stimulus Attributes	None specified
Response Attributes	None specified
Prior Knowledge	Items may require the student to apply science knowledge described in the NGSSS from lower grades. This benchmark requires prerequisite knowledge from SC.3.P.10.1, SC.3.P.10.3, SC.3.P.10.4, SC.4.P.10.1, SC.4.P.10.3, and SC.5.P.10.1.

Sample Item 19

SC.7.P.10.2

The diagram below demonstrates how a magnifying lens can make a penny appear larger.

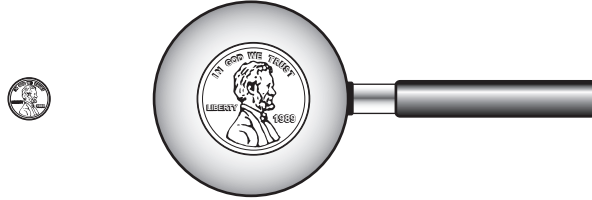

What property of the magnifying lens is **most** responsible for allowing it to magnify the penny?

- A. It can reflect light.
- ★ B. It can refract light.
- C. It can increase the intensity of light.
- D. It can increase the wavelength of light.

BENCHMARK SC.7.P.11.2

Reporting Category	Physical Science
Standard	Big Idea 11 Energy Transfer and Transformations
Benchmark	SC.7.P.11.2 Investigate and describe the transformation of energy from one form to another. (Also assesses SC.6.P.11.1 and SC.7.P.11.3.)
Also Assesses	<p>SC.6.P.11.1 Explore the Law of Conservation of Energy by differentiating between potential and kinetic energy. Identify situations where kinetic energy is transformed into potential energy and vice versa.</p> <p>SC.7.P.11.3 Cite evidence to explain that energy cannot be created nor destroyed, only changed from one form to another.</p>
Benchmark Clarifications	<p>Students will identify and/or describe the transformation of energy from one form to another.</p> <p>Students will differentiate between potential and kinetic energy.</p> <p>Students will identify and/or explain situations where energy is transformed between kinetic energy and potential energy.</p> <p>Students will identify and/or describe examples of the Law of Conservation of Energy.</p>
Content Limits	<p>Items will not assess transformations involving nuclear energy.</p> <p>Items may address a maximum of five energy transformations.</p> <p>Items will not require calculations.</p> <p>Items assessing energy transformations will not be placed in a life science context.</p>
Stimulus Attributes	None specified
Response Attributes	None specified
Prior Knowledge	Items may require the student to apply science knowledge described in the NGSSS from lower grades. This benchmark requires prerequisite knowledge from SC.3.P.11.2 and SC.5.P.10.4.

Sample Item 20

SC.7.P.11.2

Emma constructed a simple motor. When connected correctly, the coil of copper wire spins.

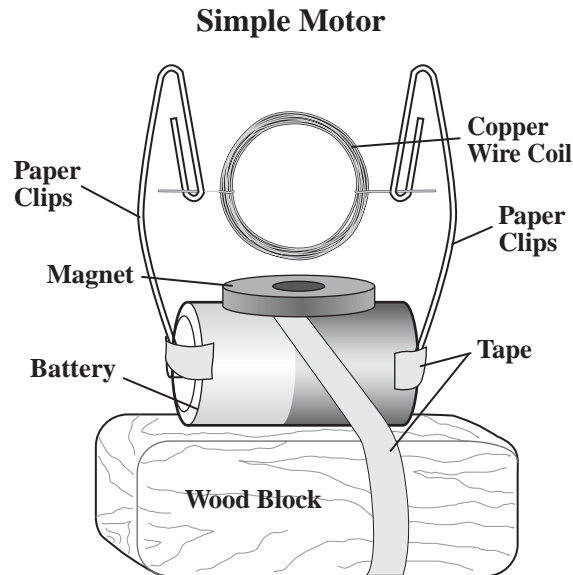

Which of the following **best** describes the energy transformation that takes place between the paper clips and the spinning coil?

- A. Chemical energy transforms into electrical energy.
- B. Mechanical energy transforms into electrical energy.
- ★ C. Electrical energy transforms into mechanical energy.
- D. Mechanical energy transforms into chemical energy.

BENCHMARK SC.7.P.11.4

Reporting Category	Physical Science
Standard	Big Idea 11 Energy Transfer and Transformations
Benchmark	SC.7.P.11.4 Observe and describe that heat flows in predictable ways, moving from warmer objects to cooler ones until they reach the same temperature. (Also assesses SC.7.P.11.1.)
Also Assesses	SC.7.P.11.1 Recognize that adding heat to or removing heat from a system may result in a temperature change and possibly a change of state.
Benchmark Clarifications	Students will describe how heat flows in predictable ways. Students will explain that adding heat to or removing heat from a system may result in a temperature change and possibly a change of state.
Content Limits	Items will not address chemical changes. Items will not require calculations. Items will not assess the concepts of conductors and insulators or examples of either in isolation. Items will not require the use or memorization of formulas or values of specific heat, heat of fusion, or heat of vaporization for substances. Items may assess the concept of specific heat.
Stimulus Attributes	Scenarios addressing methods of heat transfer (conduction, convection, radiation) will not use an Earth Science context. Temperature will only be shown in degrees Celsius (°C).
Response Attribute	Temperature will only be shown in degrees Celsius (°C).
Prior Knowledge	Items may require the student to apply science knowledge described in the NGSSS from lower grades. This benchmark requires prerequisite knowledge from SC.3.P.9.1, SC.3.P.11.1, SC.4.P.11.1, and SC.4.P.11.2.

Sample Item 21

SC.7.P.11.4

Mrs. Aldaco added a copper (Cu) cube that is at room temperature and an aluminum (Al) cube that she just removed from the freezer to a beaker of boiling water.

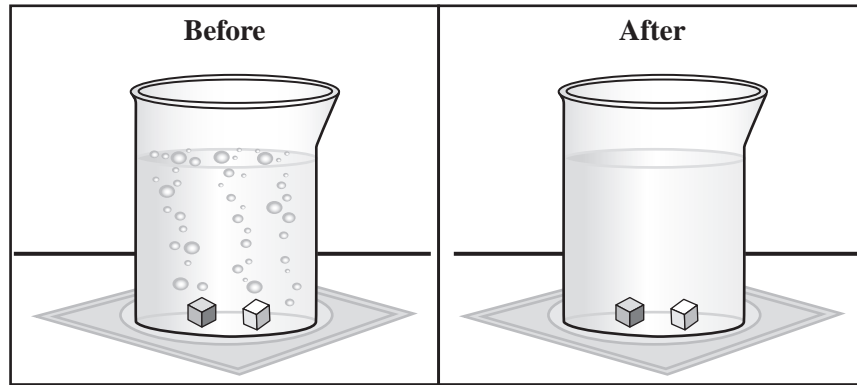

She left the cubes in the water for three hours. Which of the following describes a heat flow that took place during those three hours?

- A. from the aluminum cube to the beaker
- B. from the copper cube to the boiling water
- C. from the aluminum cube to the copper cube
- ★ D. from the boiling water to the aluminum cube

BENCHMARK SC.6.P.13.1

Reporting Category	Physical Science
Standard	Big Idea 13 Forces and Changes in Motion
Benchmark	SC.6.P.13.1 Investigate and describe types of forces including contact forces and forces acting at a distance, such as electrical, magnetic, and gravitational. (Also assesses SC.6.P.13.2 and SC.8.P.8.2.)
Also Assesses	<p>SC.6.P.13.2 Explore the Law of Gravity by recognizing that every object exerts gravitational force on every other object and that the force depends on how much mass the objects have and how far apart they are.</p> <p>SC.8.P.8.2 Differentiate between weight and mass recognizing that weight is the amount of gravitational pull on an object and is distinct from, though proportional to, mass.</p>
Benchmark Clarifications	<p>Students will identify and/or describe types of forces.</p> <p>Students will describe the relationship among distance, mass, and gravitational force between any two objects.</p> <p>Students will differentiate between mass and weight.</p>
Content Limits	<p>Items assessing gravity will use a conceptual understanding of the Law of Universal Gravitation by keeping either the mass or distance constant.</p> <p>Items will not assess nuclear forces.</p> <p>Items will not require the use of formulas or calculations.</p> <p>Items addressing mass and/or weight will not assess the units of measure for mass and weight.</p>
Stimulus Attributes	None specified
Response Attributes	None specified
Prior Knowledge	Items may require the student to apply science knowledge described in the NGSSS from lower grades. This benchmark requires prerequisite knowledge from SC.5.10.3 and SC.5.P.13.1.

Sample Item 22 **SC.6.P.13.1**

Luis rubbed a balloon on his hair and held the balloon next to the wall. He observed the balloon stick to the wall. Which of the following is responsible for the balloon sticking to the wall?

- A. friction
- B. gravity
- ★ C. electric force
- D. magnetic force

BENCHMARK SC.6.P.13.3

Reporting Category	Physical Science
Standard	Big Idea 13 Forces and Changes in Motion
Benchmark	SC.6.P.13.3 Investigate and describe that an unbalanced force acting on an object changes its speed, or direction of motion, or both. (Also assesses SC.6.P.12.1.)
Also Assesses	SC.6.P.12.1 Measure and graph distance versus time for an object moving at a constant speed. Interpret this relationship.
Benchmark Clarifications	<p>Students will describe and/or explain that an unbalanced force acting on an object changes its speed and/or direction.</p> <p>Students will interpret and/or analyze graphs of distance and time for an object moving at a constant speed.</p>
Content Limits	<p>Items requiring the interpretation and/or analysis of a graph may assess the relative speed of an object at various points or sections of the graph and the direction of motion.</p> <p>Items will not require a comparison of the speeds of more than five different objects.</p> <p>Items will not assess the addition of nonparallel vectors.</p> <p>Items will not require the calculation of acceleration.</p> <p>Items may require the calculation of net force.</p> <p>Items may assess the direction of net force.</p> <p>Items addressing force and motion are limited to conceptual understanding. Items will not require the use of the formula $F=ma$.</p> <p>Items addressing changes in speed should use the terms <i>positive acceleration</i> and <i>negative acceleration</i>.</p> <p>Items may assess understanding of friction as a force in both sliding and stationary situations. Items will not require knowledge of coefficient of friction.</p> <p>Items will not imply that a calculation is required in scenarios assessing understanding of no acceleration or no net force.</p>

Stimulus Attributes	Force diagrams may have a maximum of two sets of parallel forces acting on an object. Scenarios addressing the calculation of a average speed will not require the calculation of speed using data from a g raph. Graphs of distance and time may include no more than f ive constant speeds.
Response Attribute	Responses will not require the creation of g raphs.
Prior Knowledge	Items may require the student to apply science knowledge described in the NGSSS from lower grades. This benchmark requires prerequisite knowledge from SC.3.P.10.2, SC.4.P.10.2, SC.4.P.10.4, SC.4.P.12.1, SC.4.P.12.2, SC.5.P.10.2, SC.5.P.13.2, SC.5.P.13.3, and SC.5.P.13.4.

Sample Item 23 **SC.6.P.13.3**

The diagram below shows forces acting on a model air plane. Both its speed and height above the ground are constant.

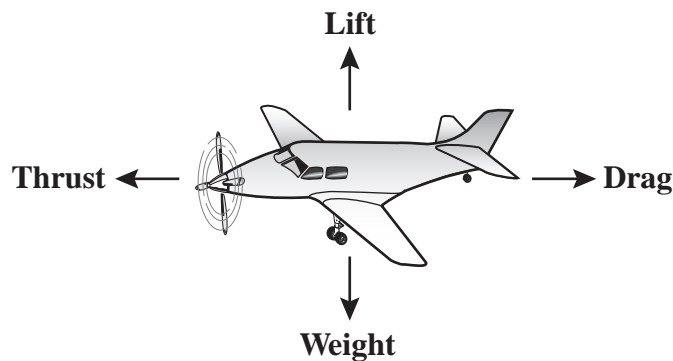

Which of the following conditions would cause the model airplane to descend toward the ground?

- A. The lift is equal to the drag.
- ★ B. The lift is less than the weight.
- C. The thrust is equal to the weight.
- D. The thrust is greater than the drag.

BENCHMARK SC.6.L.14.1

Reporting Category	Life Science
Standard	Big Idea 14 Organization and Development of Living Organisms
Benchmark	SC.6.L.14.1 Describe and identify patterns in the hierarchical organization of organisms from atoms to molecules and cells to tissues to organs to organ systems to organisms.
Benchmark Clarification	Students will identify and/or describe patterns in the hierarchical organization of organisms, from atoms to molecules, to cells, to tissues, to organs, to organ systems, to organisms.
Content Limits	Items will not assess cell specialization. Items may use the terms for the types of tissues in animals (epithelial, muscle, nervous, connective) but will not assess knowledge of the structure or function of these types of tissues.
Stimulus Attribute	Scenarios referring to atoms and molecules are limited to biotic contexts.
Response Attributes	None specified
Prior Knowledge	This benchmark grouping is foundational. These concepts have not been introduced in the NGSSS prior to this grade-level grouping.

Sample Item 24

SC.6.L.14.1

Structures in the human body work together to perform specific functions. The diagram below shows the organization of structures found in the human body.

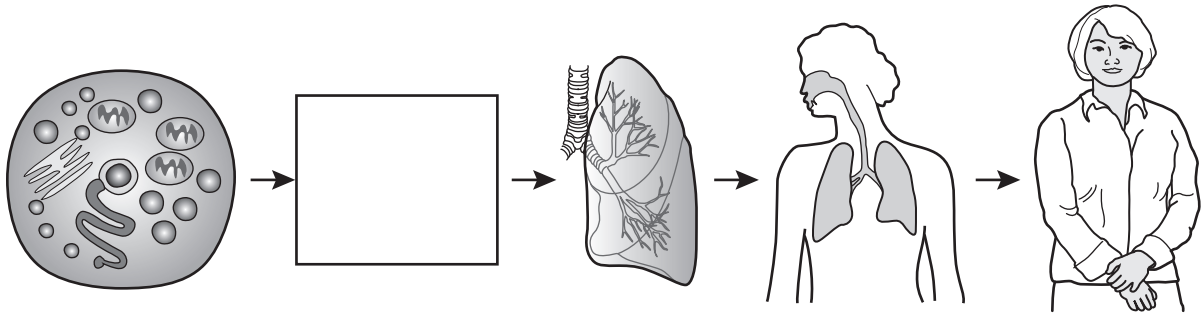

A picture of which of the following structures belongs in the box above?

- A. cell
- B. organ
- C. organelle
- ★ D. tissue

BENCHMARK SC.6.L.14.2

Reporting Category	Life Science
Standard	Big Idea 14 Organization and Development of Living Organisms
Benchmark	SC.6.L.14.2 Investigate and explain the components of the scientific theory of cells (cell theory): all organisms are composed of cells (single-celled or multi-cellular), all cells come from pre-existing cells, and cells are the basic unit of life. (Also assesses SC.6.L.14.3.)
Also Assesses	SC.6.L.14.3 Recognize and explore how cells of all organisms undergo similar processes to maintain homeostasis, including extracting energy from food, getting rid of waste, and reproducing.
Benchmark Clarifications	<p>Students will identify, describe, and/or explain the components of cell theory.</p> <p>Students will describe how cells undergo similar processes to maintain homeostasis.</p>
Content Limits	<p>Items will assess neither scientists who contributed to the cell theory nor the historical development of the cell theory.</p> <p>Items addressing homeostasis should focus on cells maintaining homeostasis and are limited to the cellular level. Items will not address permeability, osmosis, or diffusion.</p> <p>Items may use the terms <i>cellular respiration</i> and <i>photosynthesis</i> in the context of homeostasis and the functions of cell structures but will not assess knowledge of these processes.</p> <p>Items will not assess cellular reproduction.</p>
Stimulus Attributes	None specified
Response Attributes	None specified
Prior Knowledge	This benchmark grouping is foundational. These concepts have not been introduced in the NGSSS prior to this grade-level grouping.

Sample Item 25

SC.6.L.14.2

The cell theory applies to all organisms, including the five shown below.

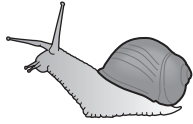
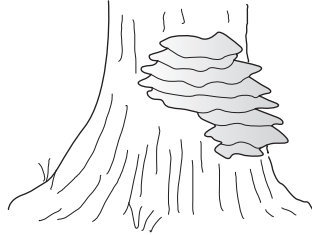
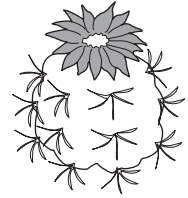
Drawings of Five Organisms**Snail****Butterfly****Shelf Fungi****Euglena****Cactus**

Which of the following statements describes how these organisms are an example of the cell theory?

- A. The organisms have cells that lack a nucleus.
- ★ B. The organisms are made of one or more cells.
- C. The cells of the organisms undergo photosynthesis.
- D. The cells of the organisms are identical to each other.

BENCHMARK SC.6.L.14.4

Reporting Category	Life Science
Standard	Big Idea 14 Organization and Development of Living Organisms
Benchmark	SC.6.L.14.4 Compare and contrast the structure and function of major organelles of plant and animal cells, including cell wall, cell membrane, nucleus, cytoplasm, chloroplasts, mitochondria, and vacuoles.
Benchmark Clarification	Students will compare and/or contrast the structure and/or function of major organelles of plant and animal cells.
Content Limit	Items assessing cellular structures are limited to the cell wall, cell membrane, nucleus, cytoplasm, chloroplasts, mitochondria, and vacuoles.
Stimulus Attribute	Scenarios will require a comparison or contrast of organelles in plant and/or animal cells.
Response Attributes	None specified
Prior Knowledge	This benchmark grouping is foundational. These concepts have not been introduced in the NGSSS prior to this grade-level grouping.

Sample Item 26

SC.6.L.14.4

Plant cells are different from animal cells. The diagram below identifies four different structures in a plant cell.

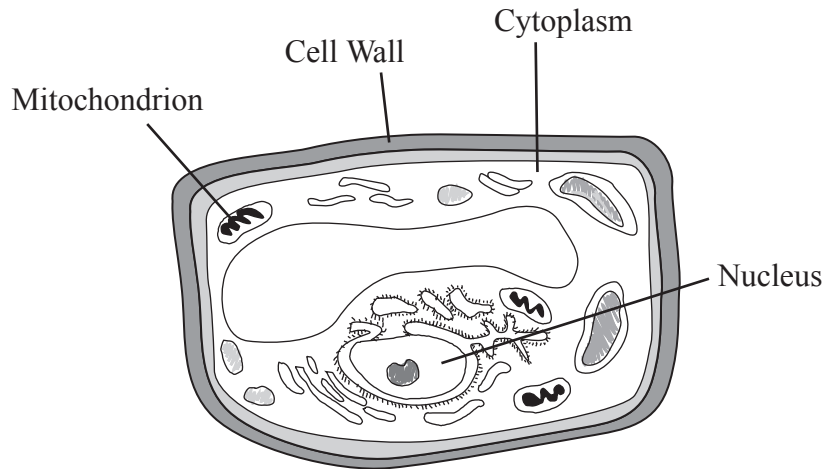

Compared to the structures in an animal cell, which of the following structures is found only in a plant cell?

- A. Mitochondrion
- ★ B. Cell Wall
- C. Cytoplasm
- D. Nucleus

BENCHMARK SC.6.L.14.5

Reporting Category	Life Science
Standard	Big Idea 14 Organization and Development of Living Organisms
Benchmark	SC.6.L.14.5 Identify and investigate the general functions of the major systems of the human body (digestive, respiratory, circulatory, reproductive, excretory, immune, nervous, and musculoskeletal) and describe ways these systems interact with each other to maintain homeostasis. (Also assesses SC.6.14.6.)
Also Assesses	SC.6.L.14.6 Compare and contrast types of infectious agents that may infect the human body, including viruses, bacteria, fungi, and parasites.
Benchmark Clarifications	<p>Students will identify and/or describe the general functions of the major systems of the human body.</p> <p>Students will identify and/or describe how the major systems of the human body interact to maintain homeostasis.</p> <p>Students will identify, compare, and/or contrast the types of infectious agents that affect the human body.</p>
Content Limits	<p>Items are limited to the human digestive, respiratory, circulatory, reproductive, excretory, immune, nervous, and musculoskeletal systems.</p> <p>Items will not assess the structures or functions of individual organs in isolation.</p> <p>Items assessing the interactions of systems to maintain homeostasis should include a reference to homeostasis and are limited to the organismal level.</p> <p>Items will not require specific knowledge of diseases that affect the human body or their causal agents.</p> <p>Items may assess the interactions of no more than three systems.</p>
Stimulus Attribute	Diagrams of the human reproductive system will not be used.
Response Attributes	None specified
Prior Knowledge	Items may require the student to apply science knowledge described in the NGSSS from lower grades. This benchmark requires prerequisite knowledge from SC.5.L.14.1 and SC.5.L.14.2.

Sample Item 27 **SC.6.L.14.5**

In order to maintain homeostasis, the systems of the human body work together to keep a constant internal temperature. Which of the following statements describes how the human body responds in a cold environment?

- A. The nervous system moves the jaw bones and causes the chattering of teeth.
- ★ B. The nervous system signals the muscles of the muscular system to contract and warm the body.
- C. The circulatory system delivers less carbon dioxide to the muscular system, resulting in stiffening of the muscles.
- D. The skeletal system produces more blood cells that circulate through the blood vessels, increasing the warmth of the body.

BENCHMARK SC.6.L.15.1

Reporting Category	Life Science
Standard	Big Idea 15 Diversity and Evolution of Living Organisms
Benchmark	SC.6.L.15.1 Analyze and describe how and why organisms are classified according to shared characteristics with emphasis on the Linnaean system combined with the concept of Domains.
Benchmark Clarification	Students will analyze and/or describe how and/or why organisms are classified.
Content Limits	<p>Items may assess how characteristics are used to classify organisms but will not assess specific characteristics of individual types of organisms.</p> <p>Items assessing the classification of organisms into domains are limited to Bacteria, Archaea, and Eukarya. Items assessing the classification of organisms into kingdoms are limited to Eubacteria, Archaea, Protist, Fungus, Plant, and Animal.</p> <p>Items may assess knowledge of the hierarchy of classification but will not assess the specific characteristics of organisms classified in a particular phylum, class, order, family, genus, or species.</p> <p>Items may use scientific names and the term <i>binomial nomenclature</i> but will not require specific knowledge of an organism's scientific name and common name.</p>
Stimulus Attributes	None specified
Response Attributes	None specified
Prior Knowledge	Items may require the student to apply science knowledge described in the NGSSS from lower grades. This benchmark requires prerequisite knowledge from SC.3.L.15.1, SC.3.L.15.2, and SC.5.L.14.2.

Sample Item 28 **SC.6.L.15.1**

Mushrooms, bread molds, and yeasts are classified together in the fungi kingdom. Specific characteristics are used to classify these organisms. Which of the following is a characteristic used to classify these organisms as fungi?

- A. They are parasites.
- B. They are unicellular.
- C. They are prokaryotes.
- ★ D. They are heterotrophs.

BENCHMARK SC.7.L.15.2

Reporting Category	Life Science
Standard	Big Idea 15 Diversity and Evolution of Living Organisms
Benchmark	SC.7.L.15.2 Explore the scientific theory of evolution by recognizing and explaining ways in which genetic variation and environmental factors contribute to evolution by natural selection and diversity of organisms. (Also assesses SC.7.L.15.1 and SC.7.L.15.3.)
Also Assesses	<p>SC.7.L.15.1 Recognize that fossil evidence is consistent with the scientific theory of evolution that living things evolved from earlier species.</p> <p>SC.7.L.15.3 Explore the scientific theory of evolution by relating how the inability of a species to adapt within a changing environment may contribute to the extinction of that species.</p>
Benchmark Clarifications	<p>Students will identify and/or explain ways in which genetic variation and environmental factors contribute to evolution by natural selection and diversity of organisms.</p> <p>Students will identify and/or explain ways in which fossil evidence is consistent with the scientific theory of evolution.</p> <p>Students will identify and/or explain how a species' inability to adapt may contribute to the extinction of that species.</p>
Content Limits	<p>Items will not address topics such as speciation, genetic drift, or gene pools.</p> <p>Items will not assess or address hominid evolution or primate fossils.</p> <p>Items assessing fossil evidence should focus on progressions over time/evolution from earlier species and/or the idea that not all species alive today were alive in the past.</p> <p>Items will not assess fossils in the context of relative dating or plate tectonics/continental movement.</p>
Stimulus Attributes	None specified
Response Attributes	None specified
Prior Knowledge	Items may require the student to apply science knowledge described in the NGSSS from lower grades. This benchmark requires prerequisite knowledge from SC.5.L.15.1 and SC.5.L.17.1.

Sample Item 29 **SC.7.L.15.3**

A certain reptile species is a herbivore and exists only on an isolated island. Which of the following would **most likely** result in the extinction of the reptile species over a period of twenty thousand years?

- A. The reptile species produces many offspring with many unique traits, and the vegetation remains constant.
- B. The reptile species produces few offspring with some unique traits, and the vegetation remains constant.
- ★ C. The reptile species produces few offspring with no unique traits, and the vegetation changes quickly.
- D. The reptile species produces many offspring with some unique traits, and the vegetation changes slowly.

BENCHMARK SC.7.L.16.1

Reporting Category	Life Science
Standard	Big Idea 16 Heredity and Reproduction
Benchmark	SC.7.L.16.1 Understand and explain that every organism requires a set of instructions that specifies its traits, that this hereditary information (DNA) contains genes located in the chromosomes of each cell, and that heredity is the passage of these instructions from one generation to another. (Also assesses SC.7.L.16.2 and SC.7.L.16.3.)
Also Assesses	<p>SC.7.L.16.2 Determine the probabilities for genotype and phenotype combinations using Punnett Squares and pedigrees.</p> <p>SC.7.L.16.3 Compare and contrast the general processes of sexual reproduction requiring meiosis and asexual reproduction requiring mitosis.</p>
Benchmark Clarifications	<p>Students will describe and/or explain that every organism requires a set of instructions that specifies its traits.</p> <p>Students will identify and/or explain that hereditary information (DNA) contains genes located in the chromosomes of each cell and/or that heredity is the passage of these instructions from one generation to another.</p> <p>Students will use Punnett squares and pedigrees to determine genotypic and phenotypic probabilities.</p> <p>Students will compare and/or contrast general processes of sexual and asexual reproduction that result in the passage of hereditary information from one generation to another.</p>
Content Limits	<p>Items may assess the general concepts of mitosis and meiosis but will not assess the phases of mitosis or meiosis. Items will not use the terms <i>haploid</i> or <i>diploid</i>.</p> <p>Items referring to sexual reproduction will not address human reproduction.</p> <p>Items addressing Punnett squares or pedigrees will only assess dominant and recessive traits.</p> <p>Items addressing pedigrees are limited to assessing the probability of a genotype or phenotype of a single individual. Items may require the identification of parental genotypes that result in certain genotypic or phenotypic probabilities in offspring.</p>

Content Limits	<p>Items will not assess incomplete dominance, sex-linked traits, polygenic traits, multiple alleles, or codominance.</p> <p>Items addressing Punnett squares are limited to the P and F₁ generations.</p> <p>Items will not assess mutation.</p> <p>Items will not address or assess the stages of meiosis, fertilization, or zygote formation.</p> <p>Items will not address or assess human genetic disorders or diseases.</p>
Stimulus Attribute	<p>Genotype and phenotype probabilities will only be in percent.</p>
Response Attribute	<p>Options may be in the form of percents or percentages.</p>
Prior Knowledge	<p>Items may require the student to apply science knowledge described in the NGSSS from lower grades. This benchmark requires prerequisite knowledge from SC.4.L.16.1, SC.4.L.16.2, and SC.4.L.16.3.</p>

Sample Item 30

SC.7.L.16.2

The gene for curled ears (C) is dominant over the gene for straight ears (c). The picture below shows a cat with curled ears (Cc) and a cat with straight ears (cc).



Curled Ears

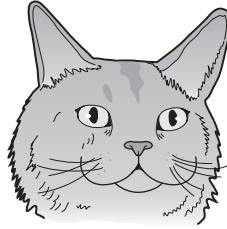

Straight Ears

What **percent** of the offspring are expected to have curled ears as a result of a cross between the cats shown?

- A. 100
- B. 75
- ★ C. 50
- D. 25

BENCHMARK SC.7.L.17.2

Reporting Category	Life Science
Standard	Big Idea 17 Interdependence
Benchmark	SC.7.L.17.2 Compare and contrast the relationships among organisms such as mutualism, predation, parasitism, competition, and commensalism. (Also assesses SC.7.L.17.1 and SC.7.L.17.3.)
Also Assesses	<p>SC.7.L.17.1 Explain and illustrate the roles of and relationships among producers, consumers, and decomposers in the process of energy transfer in a food web.</p> <p>SC.7.L.17.3 Describe and investigate various limiting factors in the local ecosystem and their impact on native populations, including food, shelter, water, space, disease, parasitism, predation, and nesting sites.</p>
Benchmark Clarifications	<p>Students will compare and/or contrast relationships between organisms, such as mutualism, predation, parasitism, competition, and commensalism.</p> <p>Students will describe and/or explain the roles of and relationships among producers, consumers, and decomposers in the process of energy transfer in a food web.</p> <p>Students will identify and/or describe various limiting factors in an ecosystem and their impact on native populations.</p>
Content Limits	<p>Items assessing the relationships between organisms may require the identification of the relationship as mutualism, predation, parasitism, competition, or commensalism.</p> <p>Items assessing the relationships of organisms may require recognition of common examples of mutualism, predation, parasitism, competition, and/or commensalism.</p> <p>Items will not require specific knowledge of organisms.</p> <p>Items may assess food webs but will not assess food chains.</p> <p>Items assessing consumers in a food web are limited to primary, secondary, and tertiary consumers.</p> <p>Items will not assess that the Sun is the source of energy for living things in isolation.</p> <p>Items will not address energy pyramids or use the term <i>trophic level</i>.</p>
Stimulus Attribute	Food webs may include a maximum of 15 organisms.

Response Attributes None specified

Prior Knowledge Items may require the student to apply science knowledge described in the NGSSS from lower grades. This benchmark requires prerequisite knowledge from SC.4.L.17.2, SC.4.L.17.3, and SC.4.L.17.4.

Sample Item 31 **SC.7.L.17.2**

Mangrove trees are common to the Florida Everglades. The tree roots serve as a place for freshwater oysters to attach when the tide is high, as shown in the picture below. The oysters are protected from predators when attached to the roots underwater.

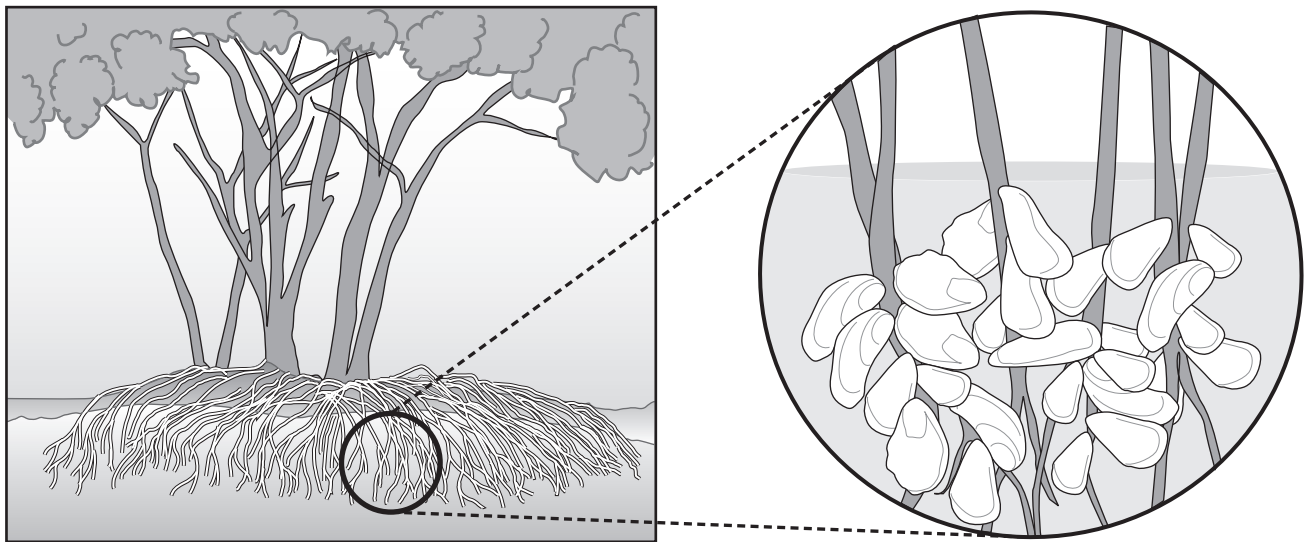

Mangrove Tree

Oysters on Mangrove Roots

The oysters do not harm the trees nor do they provide any benefit to the trees. Which of the following relationships is **most** similar to the relationship between the mangrove trees and the oysters?

- A. African ants living in acacia trees feed on leaf-eating insects found on the tree.
- B. Spider crabs are camouflaged by the green-brown algae growing on their shells.
- ★ C. A whale is unaffected by the attached remora fish feeding on the whale's leftover food.
- D. Bees fly from one flowering plant to another gathering nectar and pollinating the flowers.

BENCHMARK SC.8.L.18.4

Reporting Category	Life Science
Standard	Big Idea 18 Matter and Energy Transformations
Benchmark	SC.8.L.18.4 Cite evidence that living systems follow the Laws of Conservation of Mass and Energy. (Also assesses SC.8.L.18.1, SC.8.L.18.2, and SC.8.L.18.3.)
Also Assesses	<p>SC.8.L.18.1 Describe and investigate the process of photosynthesis, such as the roles of light, carbon dioxide, water and chlorophyll; production of food; release of oxygen.</p> <p>SC.8.L.18.2 Describe and investigate how cellular respiration breaks down food to provide energy and releases carbon dioxide.</p> <p>SC.8.L.18.3 Construct a scientific model of the carbon cycle to show how matter and energy are continuously transferred within and between organisms and their physical environment.</p>
Benchmark Clarifications	<p>Students will explain that living systems obey the Law of Conservation of Mass and the Law of Conservation of Energy.</p> <p>Students will describe and/or explain the general processes of photosynthesis or cellular respiration.</p> <p>Students will describe how matter and energy are transferred in the carbon cycle.</p> <p>Students will describe the role of light, carbon dioxide, water, and/or chlorophyll in the process and products of photosynthesis.</p>
Content Limits	<p>Items will not address or assess the stages of photosynthesis or cellular respiration.</p> <p>Items may not assess the interrelatedness of photosynthesis and cellular respiration.</p> <p>Items will not use the term <i>reactant</i>.</p> <p>Items will not use the term <i>ATP</i>.</p> <p>Items will not assess the function of organelles related to the processes of cellular respiration or photosynthesis.</p> <p>Items will not assess anaerobic respiration.</p> <p>Items referring to the carbon cycle may include carbon reservoirs, such as the atmosphere, organisms, fossil fuels, sediments, and oceans/water.</p>

Stimulus Attribute	Scenarios may use word equations for photosynthesis or cellular respiration; chemical equations may not be used.
Response Attributes	None specified
Prior Knowledge	Items may require the student to apply science knowledge described in the NGSSS from lower grades. This benchmark requires prerequisite knowledge from SC.3.L.17.2, SC.4.L.17.2, and SC.4.L.17.3.

Sample Item 32 **SC.8.L.18.3**

A diagram of the carbon cycle is shown below.

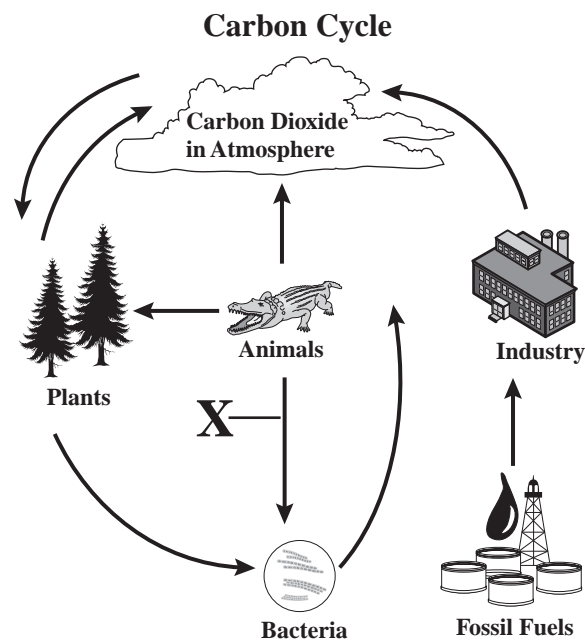

Each arrow represents a process in the cycle. Which of the following **best** describes the process that occurs at arrow X?

- ★ A. Bacteria break down molecules in animals into carbon-based soil nutrients.
- B. Animals release oxygen that is used by bacteria to produce carbon dioxide.
- C. Animals release carbon dioxide that is used by bacteria for growth and reproduction.
- D. Bacteria combine carbon-based nutrients from plants and animals to produce glucose.

APPENDIX A: DIRECTIONS FOR ITEM REVIEW AND FCAT 2.0 SCIENCE ITEM RATING FORM

Directions: A series of questions is presented below. These questions are designed to assist you with your evaluation of the quality of the FCAT 2.0 test items you will be reviewing. The table on the next page is an example of the one you will use to record your rating of each test item. Review each test item independently before discussing the items with other committee members. If you identify any problem with the item during independent review, you should put a crossmark (✗) in the appropriate column. Crossmarks (✗) will indicate a problem area, and blank spaces or checks (✓) will indicate that no problem is identified.

Questions for Individual Test Items—Record your answers on your rating sheet.

1. Does the test item assess the knowledge required by the benchmark?
2. Does the content of the test item adhere to the content limits described in the *FCAT 2.0 Science Item Specifications*?
3. Are the context and language of the test item appropriate for the grade level?
4. What is the cognitive complexity of the test item for students who have mastered the benchmark at the intended grade level? Is the item best categorized as high complexity (**H**), moderate complexity (**M**), or low complexity (**L**)?
5. Is the item clearly worded and dependent on the content (does the item flow cognitively)? If the item has art, does it enhance the item? Is the art scientifically accurate and appropriate? Is the answer free of klang? (Is the answer clued in the context?)
6. Is the assigned content focus appropriate for this item? If not, is there a better or more appropriate content focus?
7. Is there only one correct answer? Record the letter of the correct answer on the rating sheet.
8. Are the options appropriate, plausible, and parallel (both grammatically and conceptually) to the correct response and appropriate for the question asked?
9. Is the item scientifically accurate?
10. Rate the overall quality of the item using these rating definition codes:

Overall Quality	
A (Accept)	AR (Accept as Revised)
RR (Revise and Resubmit)	D (Delete)

11. Do you have any additional comments? If so, record your comments on your rating sheet in the additional comments area.

DIRECTIONS FOR ITEM REVIEW OF CONTEXT-DEPENDENT SETS

Directions: A series of questions is presented below. These questions are designed to assist you with your evaluation of the quality of the FCAT 2.0 test items you will be reviewing. The table on page A-5 is an example of the one you will use to record your rating of each context-dependent-set test item. Review each test item independently before discussing the items with other committee members. If you identify any problem with the item during independent review, you should put a crossmark (✗) in the appropriate column. Crossmarks (✗) will indicate a problem area, and blank spaces or checks (✓) will indicate that no problem is identified.

Questions for Context-Dependent Item Sets—Record your answers on the rating sheet.

Review the main context of the item set.

1. Is the context grade-level appropriate in content and language?
2. Is the main context free of klang or does it clue test items?
3. Is the context scientifically accurate?
4. Rate the overall quality of the context using these rating definition codes:

<u>Overall Quality</u>	
A (Accept)	AR (Accept as Revised)
RR (Revise and Resubmit)	D (Delete)

Read each item in the set.

5. Does the test item assess the knowledge required by the benchmark?
6. Does the content of the test item adhere to the content limits described in the *FCAT 2.0 Item Specifications*?
7. Is the item dependent on or directly related to the main context?
8. Are the context and language of the test item appropriate for this grade level?
9. What is the cognitive complexity of the test item for students who have attained the benchmark at the grade level assessed? Is the item best categorized as high complexity (**H**), moderate complexity (**M**), or low complexity (**L**)?
10. Is the answer free of klang? (Does it answer or clue other items in the set or does the main context clue an item?)
11. Is the assigned content focus appropriate for this item? If not, is there a better or more appropriate content focus?
12. Is there only one correct answer? Record the letter of the correct answer on the rating sheet.
13. Are the options appropriate, plausible, and parallel (both grammatically and conceptually) to the correct response and appropriate for the question asked?

14. Is the item scientifically accurate?
15. Rate the overall quality of the item using these rating definition codes:

<u>Overall Quality</u>	
A (Accept)	AR (Accept as Revised)
RR (Revise and Resubmit)	D (Delete)

16. Do you have any additional comments? If so, record your comments on your rating sheet in the additional comments area.

FCAT 2.0 SCIENCE ITEM RATING FORM

Signature _____ Date _____	Students in my (classroom, school, district) [circle one] are given the opportunity to learn the (Grade 5, Grade 8) [circle one] material that these items test, except as noted in my comments.
----------------------------	--

Context-Dependent Set: Main Context													
Page Number	Context Code	Is Grade Appropriate	Is Clear and Free of Klang	Is Scientifically Accurate	Overall Rating A/AR/RR/D	Additional Comments							
Context-Dependent Set: Items													
Page Number	Florida ID	Measures Benchmark	Adheres to Content Limits	Is Dependent or Related	Is Grade Appropriate	Appropriate Cognitive Complexity (L, M, H)	Is Clear and Free of Klang	Appropriate Content Focus	Only One Correct Answer (MC items)	Appropriate MC Options	Is Scientifically Accurate	Overall Rating A/AR/RR/D	Additional Comments

APPENDIX B: SCIENCE CONTENT ASSESSED BY GRADE 8 FCAT 2.0 SCIENCE

Big Idea 1 The Practice of Science		
Grade 6 Benchmark	Grade 7 Benchmark	Grade 8 Benchmark
<p>SC.6.N.1.1 Define a problem from the sixth grade curriculum, use appropriate reference materials to support scientific understanding, plan and carry out scientific investigation of various types, such as systematic observations or experiments, identify variables, collect and organize data, interpret data in charts, tables, and graphics, analyze information, make predictions, and defend conclusions.</p> <p style="text-align: right;">Assessed as SC.8.N.1.1.</p>	<p>SC.7.N.1.1 Define a problem from the seventh grade curriculum, use appropriate reference materials to support scientific understanding, plan and carry out scientific investigation of various types, such as systematic observations or experiments, identify variables, collect and organize data, interpret data in charts, tables, and graphics, analyze information, make predictions, and defend conclusions.</p> <p style="text-align: right;">Assessed as SC.8.N.1.1.</p>	<p>SC.8.N.1.1 Define a problem from the eighth grade curriculum using appropriate reference materials to support scientific understanding, plan and carry out scientific investigations of various types, such as systematic observations or experiments, identify variables, collect and organize data, interpret data in charts, tables, and graphics, analyze information, make predictions, and defend conclusions.</p> <p style="text-align: right;">Also assesses SC.6.N.1.1, SC.6.N.1.3, SC.7.N.1.1, SC.7.N.1.3, SC.7.N.1.4, SC.8.N.1.3, and SC.8.N.1.4.</p> <p style="text-align: center;">AA MC</p>
<p>SC.6.N.1.2 Explain why scientific investigations should be replicable.</p> <p style="text-align: right;">Assessed as SC.7.N.1.2.</p>	<p>SC.7.N.1.2 Differentiate replication (by others) from repetition (multiple trials).</p> <p style="text-align: right;">Also assesses SC.6.N.1.2, SC.6.N.1.4, and SC.8.N.1.2.</p> <p style="text-align: center;">AA MC</p>	<p>SC.8.N.1.2 Design and conduct a study using repeated trials and replication.</p> <p style="text-align: right;">Assessed as SC.7.N.1.2.</p>
<p>SC.6.N.1.3 Explain the difference between an experiment and other types of scientific investigation, and explain the relative benefits and limitations of each.</p> <p style="text-align: right;">Assessed as SC.8.N.1.1.</p>	<p>SC.7.N.1.3 Distinguish between an experiment (which must involve the identification and control of variables) and other forms of scientific investigation and explain that not all scientific knowledge is derived from experimentation.</p> <p style="text-align: right;">Assessed as SC.8.N.1.1.</p>	<p>SC.8.N.1.3 Use phrases such as “results support” or “fail to support” in science, understanding that science does not offer conclusive ‘proof’ of a knowledge claim.</p> <p style="text-align: right;">Assessed as SC.8.N.1.1.</p>

AA = annually assessed benchmark
MC = multiple choice

Standards marked as *Not Assessed* are more appropriately assessed through classroom instruction.

APPENDIX B: SCIENCE CONTENT ASSESSED BY GRADE 8 FCAT 2.0 SCIENCE

Big Idea 1 The Practice of Science		
Grade 6 Benchmark	Grade 7 Benchmark	Grade 8 Benchmark
<p>SC.6.N.1.4 Discuss, compare, and negotiate methods used, results obtained, and explanations among groups of students conducting the same investigation.</p> <p style="text-align: right;">Assessed as SC.7.N.1.2.</p>	<p>SC.7.N.1.4 Identify test variables (independent variables) and outcome variables (dependent variables) in an experiment.</p> <p style="text-align: right;">Assessed as SC.8.N.1.1.</p>	<p>SC.8.N.1.4 Explain how hypotheses are valuable if they lead to further investigations, even if they turn out not to be supported by the data.</p> <p style="text-align: right;">Assessed as SC.8.N.1.1.</p>
<p>SC.6.N.1.5 Recognize that science involves creativity, not just in designing experiments, but also in creating explanations that fit evidence.</p> <p style="text-align: right;">Not Assessed.</p>	<p>SC.7.N.1.5 Describe the methods used in the pursuit of a scientific explanation as seen in different fields of science such as biology, geology, and physics.</p> <p style="text-align: right;">Also assesses SC.7.N.3.2, SC.8.N.1.5, and SC.8.E.5.10.</p> <p style="text-align: center;">AA MC</p>	<p>SC.8.N.1.5 Analyze the methods used to develop a scientific explanation as seen in different fields of science.</p> <p style="text-align: right;">Assessed as SC.7.N.1.5.</p>
	<p>SC.7.N.1.6 Explain that empirical evidence is the cumulative body of observations of a natural phenomenon on which scientific explanations are based.</p> <p style="text-align: right;">Assessed as SC.6.N.2.2.</p>	<p>SC.8.N.1.6 Understand that scientific investigations involve the collection of relevant empirical evidence, the use of logical reasoning, and the application of imagination in devising hypotheses, predictions, explanations and models to make sense of the collected evidence.</p> <p style="text-align: right;">Assessed as SC.6.N.2.2.</p>
	<p>SC.7.N.1.7 Explain that scientific knowledge is the result of a great deal of debate and confirmation within the science community.</p> <p style="text-align: right;">Assessed as SC.6.N.2.2.</p>	

AA = annually assessed benchmark
MC = multiple choice

Standards marked as *Not Assessed* are more appropriately assessed through classroom instruction.

APPENDIX B: SCIENCE CONTENT ASSESSED BY GRADE 8 FCAT 2.0 SCIENCE

Big Idea 2 The Characteristics of Scientific Knowledge		
Grade 6 Benchmark	Grade 7 Benchmark	Grade 8 Benchmark
<p>SC.6.N.2.1 Distinguish science from other activities involving thought.</p> <p style="text-align: right;">Not Assessed.</p>	<p>SC.7.N.2.1 Identify an instance from the history of science in which scientific knowledge has changed when new evidence or new interpretations are encountered.</p> <p style="text-align: center;">Assessed as SC.6.N.2.2.</p>	<p>SC.8.N.2.1 Distinguish between scientific and pseudoscientific ideas.</p> <p style="text-align: right;">Not Assessed.</p>
<p>SC.6.N.2.2 Explain that scientific knowledge is durable because it is open to change as new evidence or interpretations are encountered.</p> <p style="text-align: center;">Also assesses SC.7.N.1.6, SC.7.N.1.7, SC.7.N.2.1, and SC.8.N.1.6.</p> <p>AA MC</p>		<p>SC.8.N.2.2 Discuss what characterizes science and its methods.</p> <p style="text-align: right;">Not Assessed.</p>
<p>SC.6.N.2.3 Recognize that scientists who make contributions to scientific knowledge come from all kinds of backgrounds and possess varied talents, interests, and goals.</p> <p style="text-align: right;">Not Assessed.</p>		

AA = annually assessed benchmark
MC = multiple choice

Standards marked as *Not Assessed* are more appropriately assessed through classroom instruction.

APPENDIX B: SCIENCE CONTENT ASSESSED BY GRADE 8 FCAT 2.0 SCIENCE

Big Idea 3 The Role of Theories, Laws, Hypotheses, and Models		
Grade 6 Benchmark	Grade 7 Benchmark	Grade 8 Benchmark
<p>SC.6.N.3.1 Recognize and explain that a scientific theory is a well-supported and widely accepted explanation of nature and is not simply a claim posed by an individual. Thus, the use of the term theory in science is very different than how it is used in everyday life.</p> <p style="text-align: right;">Assessed as SC.7.N.3.1.</p>	<p>SC.7.N.3.1 Recognize and explain the difference between theories and laws and give several examples of scientific theories and the evidence that supports them.</p> <p style="text-align: center;">Also assesses SC.6.N.3.1 and SC.8.N.3.2.</p> <p style="text-align: center;">AA MC</p>	<p>SC.8.N.3.1 Select models useful in relating the results of their own investigations.</p> <p style="text-align: right;">Not Assessed.</p>
<p>SC.6.N.3.2 Recognize and explain that a scientific law is a description of a specific relationship under given conditions in the natural world. Thus, scientific laws are different from societal laws.</p> <p style="text-align: right;">Not Assessed.</p>	<p>SC.7.N.3.2 Identify the benefits and limitations of the use of scientific models.</p> <p style="text-align: right;">Assessed as SC.7.N.1.5.</p>	<p>SC.8.N.3.2 Explain why theories may be modified but are rarely discarded.</p> <p style="text-align: right;">Assessed as SC.7.N.3.1.</p>
<p>SC.6.N.3.3 Give several examples of scientific laws.</p> <p style="text-align: right;">Not Assessed.</p>		
<p>SC.6.N.3.4 Identify the role of models in the context of the sixth grade science benchmarks.</p> <p style="text-align: right;">Not Assessed.</p>		

AA = annually assessed benchmark
MC = multiple choice

Standards marked as *Not Assessed* are more appropriately assessed through classroom instruction.

APPENDIX B: SCIENCE CONTENT ASSESSED BY GRADE 8 FCAT 2.0 SCIENCE

Big Idea 4 Science and Society		
Grade 6 Benchmark	Grade 7 Benchmark	Grade 8 Benchmark
		<p>SC.8.N.4.1 Explain that science is one of the processes that can be used to inform decision making at the community, state, national, and international levels.</p> <p style="text-align: right;">Not Assessed.</p>
		<p>SC.8.N.4.2 Explain how political, social, and economic concerns can affect science, and vice versa.</p> <p style="text-align: right;">Not Assessed.</p>
Big Idea 5 Earth in Space and Time		
Grade 6 Benchmark	Grade 7 Benchmark	Grade 8 Benchmark
		<p>SC.8.E.5.1 Recognize that there are enormous distances between objects in space and apply our knowledge of light and space travel to understand this distance.</p> <p style="text-align: right;">Assessed as SC.8.E.5.3.</p>
		<p>SC.8.E.5.2 Recognize that the universe contains many billions of galaxies and that each galaxy contains many billions of stars.</p> <p style="text-align: right;">Assessed as SC.8.E.5.3.</p>

AA = annually assessed benchmark
MC = multiple choice

Standards marked as *Not Assessed* are more appropriately assessed through classroom instruction.

APPENDIX B: SCIENCE CONTENT ASSESSED BY GRADE 8 FCAT 2.0 SCIENCE

Big Idea 5 Earth in Space and Time		
Grade 6 Benchmark	Grade 7 Benchmark	Grade 8 Benchmark
		<p>SC.8.E.5.3 Distinguish the hierarchical relationships between planets and other astronomical bodies relative to solar system, galaxy, and universe, including distance, size, and composition.</p> <p style="text-align: right;">Also assesses SC.8.E.5.1 and SC.8.E.5.2.</p> <p>AA MC</p>
		<p>SC.8.E.5.4 Explore the Law of Universal Gravitation by explaining the role that gravity plays in the formation of planets, stars, and solar systems and in determining their motions.</p> <p style="text-align: right;">Assessed as SC.8.E.5.7.</p>
		<p>SC.8.E.5.5 Describe and classify specific physical properties of stars: apparent magnitude (brightness), temperature (color), size, and luminosity (absolute brightness).</p> <p style="text-align: right;">Also assesses SC.8.E.5.6.</p> <p>AA MC</p>
		<p>SC.8.E.5.6 Create models of solar properties including: rotation, structure of the Sun, convection, sunspots, solar flares, and prominences.</p> <p style="text-align: right;">Assessed as SC.8.E.5.5.</p>

AA = annually assessed benchmark
MC = multiple choice

Standards marked as *Not Assessed* are more appropriately assessed through classroom instruction.

APPENDIX B: SCIENCE CONTENT ASSESSED BY GRADE 8 FCAT 2.0 SCIENCE

Big Idea 5 Earth in Space and Time		
Grade 6 Benchmark	Grade 7 Benchmark	Grade 8 Benchmark
		<p>SC.8.E.5.7 Compare and contrast the properties of objects in the Solar System including the Sun, planets, and moons to those of Earth, such as gravitational force, distance from the Sun, speed, movement, temperature, and atmospheric conditions.</p> <p style="text-align: right;">Also assesses SC.8.E.5.4 and SC.8.E.5.8.</p> <p>AA MC</p>
		<p>SC.8.E.5.8 Compare various historical models of the Solar System, including geocentric and heliocentric.</p> <p style="text-align: right;">Assessed as SC.8.E.5.7.</p>
		<p>SC.8.E.5.9 Explain the impact of objects in space on each other including: 1. the Sun on the Earth including seasons and gravitational attraction 2. the Moon on the Earth, including phases, tides, and eclipses, and the relative position of each body.</p> <p>AA MC</p>
		<p>SC.8.E.5.10 Assess how technology is essential to science for such purposes as access to outer space and other remote locations, sample collection, measurement, data collection and storage, computation, and communication of information.</p> <p style="text-align: right;">Assessed as SC.7.N.1.5.</p>

AA = annually assessed benchmark
MC = multiple choice

Standards marked as *Not Assessed* are more appropriately assessed through classroom instruction.

APPENDIX B: SCIENCE CONTENT ASSESSED BY GRADE 8 FCAT 2.0 SCIENCE

Big Idea 5 Earth in Space and Time		
Grade 6 Benchmark	Grade 7 Benchmark	Grade 8 Benchmark
		<p>SC.8.E.5.11 Identify and compare characteristics of the electromagnetic spectrum such as wavelength, frequency, use, and hazards and recognize its application to an understanding of planetary images and satellite photographs.</p> <p style="text-align: right;">Assessed as SC.7.P.10.1.</p>
		<p>SC.8.E.5.12 Summarize the effects of space exploration on the economy and culture of Florida.</p> <p style="text-align: right;">Not Assessed.</p>
Big Idea 6 Earth Structures		
Grade 6 Benchmark	Grade 7 Benchmark	Grade 8 Benchmark
<p>SC.6.E.6.1 Describe and give examples of ways in which Earth's surface is built up and torn down by physical and chemical weathering, erosion, and deposition.</p> <p style="text-align: right;">Assessed as SC.7.E.6.2.</p>	<p>SC.7.E.6.1 Describe the layers of the solid Earth, including the lithosphere, the hot convecting mantle, and the dense metallic liquid and solid cores.</p> <p style="text-align: right;">Assessed as SC.7.E.6.5.</p>	
<p>SC.6.E.6.2 Recognize that there are a variety of different landforms on Earth's surface such as coastlines, dunes, rivers, mountains, glaciers, deltas, and lakes and relate these landforms as they apply to Florida.</p> <p style="text-align: right;">Assessed as SC.7.E.6.2.</p>	<p>SC.7.E.6.2 Identify the patterns within the rock cycle and relate them to surface events (weathering and erosion) and sub-surface events (plate tectonics and mountain building).</p> <p style="text-align: right;">Also assesses SC.6.E.6.1, SC.6.E.6.2, and SC.7.E.6.6.</p> <p style="text-align: center;">AA MC</p>	

AA = annually assessed benchmark
MC = multiple choice

Standards marked as *Not Assessed* are more appropriately assessed through classroom instruction.

APPENDIX B: SCIENCE CONTENT ASSESSED BY GRADE 8 FCAT 2.0 SCIENCE

Big Idea 6 Earth Structures		
Grade 6 Benchmark	Grade 7 Benchmark	Grade 8 Benchmark
	<p>SC.7.E.6.3 Identify current methods for measuring the age of Earth and its parts, including the law of superposition and radioactive dating.</p> <p style="text-align: right;">Assessed as SC.7.E.6.4.</p>	
	<p>SC.7.E.6.4 Explain and give examples of how physical evidence supports scientific theories that Earth has evolved over geologic time due to natural processes.</p> <p style="text-align: right;">Also assesses SC.7.E.6.3.</p> <p>AA MC</p>	
	<p>SC.7.E.6.5 Explore the scientific theory of plate tectonics by describing how the movement of Earth's crustal plates causes both slow and rapid changes in Earth's surface, including volcanic eruptions, earthquakes, and mountain building.</p> <p style="text-align: right;">Also assesses SC.7.E.6.1 and SC.7.E.6.7.</p> <p>AA MC</p>	
	<p>SC.7.E.6.6 Identify the impact that humans have had on Earth, such as deforestation, urbanization, desertification, erosion, air and water quality, changing the flow of water.</p> <p style="text-align: right;">Assessed as SC.7.E.6.2.</p>	

AA = annually assessed benchmark
MC = multiple choice

Standards marked as *Not Assessed* are more appropriately assessed through classroom instruction.

APPENDIX B: SCIENCE CONTENT ASSESSED BY GRADE 8 FCAT 2.0 SCIENCE

Big Idea 6 Earth Structures		
Grade 6 Benchmark	Grade 7 Benchmark	Grade 8 Benchmark
	<p>SC.7.E.6.7 Recognize that heat flow and movement of material within Earth causes earthquakes and volcanic eruptions, and creates mountains and ocean basins.</p> <p style="text-align: right;">Assessed as SC.7.E.6.5.</p>	
Big Idea 7 Earth Systems and Patterns		
Grade 6 Benchmark	Grade 7 Benchmark	Grade 8 Benchmark
<p>SC.6.E.7.1 Differentiate among radiation, conduction, and convection, the three mechanisms by which heat is transferred through Earth's system.</p> <p style="text-align: right;">Assessed as SC.6.E.7.5.</p>		
<p>SC.6.E.7.2 Investigate and apply how the cycling of water between the atmosphere and hydrosphere has an effect on weather patterns and climate.</p> <p style="text-align: right;">Assessed as SC.6.E.7.4.</p>		
<p>SC.6.E.7.3 Describe how global patterns such as the jet stream and ocean currents influence local weather in measurable terms such as temperature, air pressure, wind direction and speed, and humidity and precipitation.</p> <p style="text-align: right;">Assessed as SC.6.E.7.4.</p>		

AA = annually assessed benchmark
MC = multiple choice

Standards marked as *Not Assessed* are more appropriately assessed through classroom instruction.

APPENDIX B: SCIENCE CONTENT ASSESSED BY GRADE 8 FCAT 2.0 SCIENCE

Big Idea 7 Earth Systems and Patterns		
Grade 6 Benchmark	Grade 7 Benchmark	Grade 8 Benchmark
<p>SC.6.E.7.4 Differentiate and show interactions among the geosphere, hydrosphere, cryosphere, atmosphere, and biosphere.</p> <p style="text-align: center;">Also assesses SC.6.E.7.2, SC.6.E.7.3, SC.6.E.7.6, and SC.6.E.7.9.</p> <p>AA MC</p>		
<p>SC.6.E.7.5 Explain how energy provided by the sun influences global patterns of atmospheric movement and the temperature differences between air, water, and land.</p> <p style="text-align: center;">Also assesses SC.6.E.7.1.</p> <p>AA MC</p>		
<p>SC.6.E.7.6 Differentiate between weather and climate.</p> <p style="text-align: center;">Assessed as SC.6.E.7.4.</p>		
<p>SC.6.E.7.7 Investigate how natural disasters have affected human life in Florida.</p> <p style="text-align: center;">Not Assessed.</p>		
<p>SC.6.E.7.8 Describe ways human beings protect themselves from hazardous weather and sun exposure.</p> <p style="text-align: center;">Not Assessed.</p>		

AA = annually assessed benchmark
MC = multiple choice

Standards marked as *Not Assessed* are more appropriately assessed through classroom instruction.

APPENDIX B: SCIENCE CONTENT ASSESSED BY GRADE 8 FCAT 2.0 SCIENCE

Big Idea 7 Earth Systems and Patterns		
Grade 6 Benchmark	Grade 7 Benchmark	Grade 8 Benchmark
<p>SC.6.E.7.9 Describe how the composition and structure of the atmosphere protects life and insulates the planet.</p> <p style="text-align: right;">Assessed as SC.6.E.7.4.</p>		
Big Idea 8 Properties of Matter		
Grade 6 Benchmark	Grade 7 Benchmark	Grade 8 Benchmark
		<p>SC.8.P.8.1 Explore the scientific theory of atoms (also known as atomic theory) by using models to explain the motion of particles in solids, liquids, and gases.</p> <p style="text-align: right;">Assessed as SC.8.P.8.5.</p>
		<p>SC.8.P.8.2 Differentiate between weight and mass recognizing that weight is the amount of gravitational pull on an object and is distinct from, though proportional to, mass.</p> <p style="text-align: right;">Assessed as SC.6.P.13.1.</p>
		<p>SC.8.P.8.3 Explore and describe the densities of various materials through measurement of their masses and volumes.</p> <p style="text-align: right;">Assessed as SC.8.P.8.4.</p>

AA = annually assessed benchmark
MC = multiple choice

Standards marked as *Not Assessed* are more appropriately assessed through classroom instruction.

APPENDIX B: SCIENCE CONTENT ASSESSED BY GRADE 8 FCAT 2.0 SCIENCE

Big Idea 8 Properties of Matter		
Grade 6 Benchmark	Grade 7 Benchmark	Grade 8 Benchmark
		<p>SC.8.P.8.4 Classify and compare substances on the basis of characteristic physical properties that can be demonstrated or measured; for example, density, thermal or electrical conductivity, solubility, magnetic properties, melting and boiling points, and know that these properties are independent of the amount of the sample.</p> <p style="text-align: right;">Also assesses SC.8.P.8.3.</p> <p style="text-align: left;">AA</p> <p style="text-align: right;">MC</p>
		<p>SC.8.P.8.5 Recognize that there are a finite number of elements and that their atoms combine in a multitude of ways to produce compounds that make up all of the living and nonliving things that we encounter.</p> <p style="text-align: right;">Also assesses SC.8.P.8.1, SC.8.P.8.6, SC.8.P.8.7, SC.8.P.8.8, and SC.8.P.8.9.</p> <p style="text-align: left;">AA</p> <p style="text-align: right;">MC</p>
		<p>SC.8.P.8.6 Recognize that elements are grouped in the periodic table according to similarities of their properties.</p> <p style="text-align: right;">Assessed as SC.8.P.8.5.</p>

AA = annually assessed benchmark
MC = multiple choice

Standards marked as *Not Assessed* are more appropriately assessed through classroom instruction.

APPENDIX B: SCIENCE CONTENT ASSESSED BY GRADE 8 FCAT 2.0 SCIENCE

Big Idea 8 Properties of Matter		
Grade 6 Benchmark	Grade 7 Benchmark	Grade 8 Benchmark
		<p>SC.8.P.8.7 Explore the scientific theory of atoms (also known as atomic theory) by recognizing that atoms are the smallest unit of an element and are composed of sub-atomic particles (electrons surrounding a nucleus containing protons and neutrons).</p> <p style="text-align: right;">Assessed as SC.8.P.8.5.</p>
		<p>SC.8.P.8.8 Identify basic examples of and compare and classify the properties of compounds, including acids, bases, and salts.</p> <p style="text-align: right;">Assessed as SC.8.P.8.5.</p>
		<p>SC.8.P.8.9 Distinguish among mixtures (including solutions) and pure substances.</p> <p style="text-align: right;">Assessed as SC.8.P.8.5.</p>
Big Idea 9 Changes in Matter		
Grade 6 Benchmark	Grade 7 Benchmark	Grade 8 Benchmark
		<p>SC.8.P.9.1 Explore the Law of Conservation of Mass by demonstrating and concluding that mass is conserved when substances undergo physical and chemical changes.</p> <p style="text-align: right;">Assessed as SC.8.P.9.2.</p>
		<p>SC.8.P.9.2 Differentiate between physical changes and chemical changes.</p> <p style="text-align: right;">Also assesses SC.8.P.9.1 and SC.8.P.9.3.</p> <p>AA MC</p>

AA = annually assessed benchmark
MC = multiple choice

Standards marked as *Not Assessed* are more appropriately assessed through classroom instruction.

APPENDIX B: SCIENCE CONTENT ASSESSED BY GRADE 8 FCAT 2.0 SCIENCE

Big Idea 9 Changes in Matter		
Grade 6 Benchmark	Grade 7 Benchmark	Grade 8 Benchmark
		<p>SC.8.P.9.3 Investigate and describe how temperature influences chemical changes.</p> <p style="text-align: right;">Assessed as SC.8.P.9.2.</p>
Big Idea 10 Forms of Energy		
Grade 6 Benchmark	Grade 7 Benchmark	Grade 8 Benchmark
	<p>SC.7.P.10.1 Illustrate that the sun's energy arrives as radiation with a wide range of wavelengths, including infrared, visible, and ultraviolet, and that white light is made up of a spectrum of many different colors.</p> <p style="text-align: right;">Also assesses SC.8.E.5.11.</p> <p>AA MC</p>	
	<p>SC.7.P.10.2 Observe and explain that light can be reflected, refracted, and/or absorbed.</p> <p style="text-align: right;">Assessed as SC.7.P.10.3.</p>	
	<p>SC.7.P.10.3 Recognize that light waves, sound waves, and other waves move at different speeds in different materials.</p> <p style="text-align: right;">Also assesses SC.7.P.10.2.</p> <p>AA MC</p>	

AA = annually assessed benchmark
MC = multiple choice

Standards marked as *Not Assessed* are more appropriately assessed through classroom instruction.

APPENDIX B: SCIENCE CONTENT ASSESSED BY GRADE 8 FCAT 2.0 SCIENCE

Big Idea 11 Energy Transfer and Transformations		
Grade 6 Benchmark	Grade 7 Benchmark	Grade 8 Benchmark
<p>SC.6.P.11.1 Explore the Law of Conservation of Energy by differentiating between potential and kinetic energy. Identify situations where kinetic energy is transformed into potential energy and vice versa.</p> <p style="text-align: right;">Assessed as SC.7.P.11.2.</p>	<p>SC.7.P.11.1 Recognize that adding heat to or removing heat from a system may result in a temperature change and possibly a change of state.</p> <p style="text-align: right;">Assessed as SC.7.P.11.4.</p>	
	<p>SC.7.P.11.2 Investigate and describe the transformation of energy from one form to another.</p> <p style="text-align: center;">Also assesses SC.6.P.11.1 and SC.7.P.11.3.</p> <p style="text-align: center;">AA MC</p>	
	<p>SC.7.P.11.3 Cite evidence to explain that energy cannot be created nor destroyed, only changed from one form to another.</p> <p style="text-align: right;">Assessed as SC.7.P.11.2.</p>	
	<p>SC.7.P.11.4 Observe and describe that heat flows in predictable ways, moving from warmer objects to cooler ones until they reach the same temperature.</p> <p style="text-align: right;">Also assesses SC.7.P.11.1.</p> <p style="text-align: center;">AA MC</p>	

AA = annually assessed benchmark
MC = multiple choice

Standards marked as *Not Assessed* are more appropriately assessed through classroom instruction.

APPENDIX B: SCIENCE CONTENT ASSESSED BY GRADE 8 FCAT 2.0 SCIENCE

Big Idea 12 Motion of Objects		
Grade 6 Benchmark	Grade 7 Benchmark	Grade 8 Benchmark
<p>SC.6.P.12.1 Measure and graph distance versus time for an object moving at a constant speed. Interpret this relationship.</p> <p style="text-align: right;">Assessed as SC.6.P.13.3.</p>		
Big Idea 13 Forces and Changes in Motion		
Grade 6 Benchmark	Grade 7 Benchmark	Grade 8 Benchmark
<p>SC.6.P.13.1 Investigate and describe types of forces including contact forces and forces acting at a distance, such as electrical, magnetic, and gravitational.</p> <p style="text-align: right;">Also assesses SC.6.P.13.2 and SC.8.P.8.2.</p> <p>AA MC</p>		
<p>SC.6.P.13.2 Explore the Law of Gravity by recognizing that every object exerts gravitational force on every other object and that the force depends on how much mass the objects have and how far apart they are.</p> <p style="text-align: right;">Assessed as SC.6.P.13.1.</p>		
<p>SC.6.P.13.3 Investigate and describe that an unbalanced force acting on an object changes its speed, or direction of motion, or both.</p> <p style="text-align: right;">Also assesses SC.6.P.12.1.</p> <p>AA MC</p>		

AA = annually assessed benchmark
MC = multiple choice

Standards marked as *Not Assessed* are more appropriately assessed through classroom instruction.

APPENDIX B: SCIENCE CONTENT ASSESSED BY GRADE 8 FCAT 2.0 SCIENCE

Big Idea 14 Organization and Development of Living Organisms		
Grade 6 Benchmark	Grade 7 Benchmark	Grade 8 Benchmark
<p>SC.6.L.14.1 Describe and identify patterns in the hierarchical organization of organisms from atoms to molecules and cells to tissues to organs to organ systems to organisms.</p> <p style="text-align: center;">AA MC</p>		
<p>SC.6.L.14.2 Investigate and explain the components of the scientific theory of cells (cell theory): all organisms are composed of cells (single-celled or multi-cellular), all cells come from pre-existing cells, and cells are the basic unit of life.</p> <p style="text-align: center;">Also assesses SC.6.L.14.3.</p> <p style="text-align: center;">AA MC</p>		
<p>SC.6.L.14.3 Recognize and explore how cells of all organisms undergo similar processes to maintain homeostasis, including extracting energy from food, getting rid of waste, and reproducing.</p> <p style="text-align: center;">Assessed as SC.6.L.14.2.</p>		
<p>SC.6.L.14.4 Compare and contrast the structure and function of major organelles of plant and animal cells, including cell wall, cell membrane, nucleus, cytoplasm, chloroplasts, mitochondria, and vacuoles.</p> <p style="text-align: center;">AA MC</p>		

AA = annually assessed benchmark
MC = multiple choice

Standards marked as *Not Assessed* are more appropriately assessed through classroom instruction.

APPENDIX B: SCIENCE CONTENT ASSESSED BY GRADE 8 FCAT 2.0 SCIENCE

Big Idea 14 Organization and Development of Living Organisms		
Grade 6 Benchmark	Grade 7 Benchmark	Grade 8 Benchmark
<p>SC.6.L.14.5 Identify and investigate the general functions of the major systems of the human body (digestive, respiratory, circulatory, reproductive, excretory, immune, nervous, and musculoskeletal) and describe ways these systems interact with each other to maintain homeostasis.</p> <p style="text-align: right;">Also assesses SC.6.L.14.6.</p> <p>AA MC</p>		
<p>SC.6.L.14.6 Compare and contrast types of infectious agents that may infect the human body, including viruses, bacteria, fungi, and parasites.</p> <p style="text-align: right;">Assessed as SC.6.L.14.5.</p>		
Big Idea 15 Diversity and Evolution of Living Organisms		
Grade 6 Benchmark	Grade 7 Benchmark	Grade 8 Benchmark
<p>SC.6.L.15.1 Analyze and describe how and why organisms are classified according to shared characteristics with emphasis on the Linnaean system combined with the concept of Domains.</p> <p>AA MC</p>	<p>SC.7.L.15.1 Recognize that fossil evidence is consistent with the scientific theory of evolution that living things evolved from earlier species.</p> <p style="text-align: right;">Assessed as SC.7.L.15.2.</p>	

AA = annually assessed benchmark
MC = multiple choice

Standards marked as *Not Assessed* are more appropriately assessed through classroom instruction.

APPENDIX B: SCIENCE CONTENT ASSESSED BY GRADE 8 FCAT 2.0 SCIENCE

Big Idea 15 Diversity and Evolution of Living Organisms		
Grade 6 Benchmark	Grade 7 Benchmark	Grade 8 Benchmark
	<p>SC.7.L.15.2 Explore the scientific theory of evolution by recognizing and explaining ways in which genetic variation and environmental factors contribute to evolution by natural selection and diversity of organisms.</p> <p style="text-align: center;">Also assesses SC.7.L.15.1 and SC.7.L.15.3.</p> <p>AA MC</p>	
	<p>SC.7.L.15.3 Explore the scientific theory of evolution by relating how the inability of a species to adapt within a changing environment may contribute to the extinction of that species.</p> <p style="text-align: right;">Assessed as SC.7.L.15.2.</p>	
Big Idea 16 Heredity and Reproduction		
Grade 6 Benchmark	Grade 7 Benchmark	Grade 8 Benchmark
	<p>SC.7.L.16.1 Understand and explain that every organism requires a set of instructions that specifies its traits, that this hereditary information (DNA) contains genes located in the chromosomes of each cell, and that heredity is the passage of these instructions from one generation to another.</p> <p style="text-align: center;">Also assesses SC.7.L.16.2 and SC.7.L.16.3.</p> <p>AA MC</p>	

AA = annually assessed benchmark
MC = multiple choice

Standards marked as *Not Assessed* are more appropriately assessed through classroom instruction.

APPENDIX B: SCIENCE CONTENT ASSESSED BY GRADE 8 FCAT 2.0 SCIENCE

Big Idea 16 Heredity and Reproduction		
Grade 6 Benchmark	Grade 7 Benchmark	Grade 8 Benchmark
	<p>SC.7.L.16.2 Determine the probabilities for genotype and phenotype combinations using Punnett Squares and pedigrees.</p> <p style="text-align: right;">Assessed as SC.7.L.16.1.</p>	
	<p>SC.7.L.16.3 Compare and contrast the general processes of sexual reproduction requiring meiosis and asexual reproduction requiring mitosis.</p> <p style="text-align: right;">Assessed as SC.7.L.16.1.</p>	
	<p>SC.7.L.16.4 Recognize and explore the impact of biotechnology (cloning, genetic engineering, artificial selection) on the individual, society and the environment.</p> <p style="text-align: right;">Not Assessed.</p>	
Big Idea 17 Interdependence		
Grade 6 Benchmark	Grade 7 Benchmark	Grade 8 Benchmark
	<p>SC.7.L.17.1 Explain and illustrate the roles of and relationships among producers, consumers, and decomposers in the process of energy transfer in a food web.</p> <p style="text-align: right;">Assessed as SC.7.L.17.2.</p>	

AA = annually assessed benchmark
MC = multiple choice

Standards marked as *Not Assessed* are more appropriately assessed through classroom instruction.

APPENDIX B: SCIENCE CONTENT ASSESSED BY GRADE 8 FCAT 2.0 SCIENCE

Big Idea 17 Interdependence		
Grade 6 Benchmark	Grade 7 Benchmark	Grade 8 Benchmark
	<p>SC.7.L.17.2 Compare and contrast the relationships among organisms such as mutualism, predation, parasitism, competition, and commensalism.</p> <p style="text-align: center;">Also assesses SC.7.L.17.1 and SC.7.L.17.3.</p> <p>AA MC</p>	
	<p>SC.7.L.17.3 Describe and investigate various limiting factors in the local ecosystem and their impact on native populations, including food, shelter, water, space, disease, parasitism, predation, and nesting sites.</p> <p style="text-align: right;">Assessed as SC.7.L.17.2.</p>	
Big Idea 18 Matter and Energy Transformations		
Grade 6 Benchmark	Grade 7 Benchmark	Grade 8 Benchmark
		<p>SC.8.L.18.1 Describe and investigate the process of photosynthesis, such as the roles of light, carbon dioxide, water and chlorophyll; production of food; release of oxygen.</p> <p style="text-align: right;">Assessed as SC.8.L.18.4.</p>
		<p>SC.8.L.18.2 Describe and investigate how cellular respiration breaks down food to provide energy and releases carbon dioxide.</p> <p style="text-align: right;">Assessed as SC.8.L.18.4.</p>

AA = annually assessed benchmark
MC = multiple choice

Standards marked as *Not Assessed* are more appropriately assessed through classroom instruction.

APPENDIX B: SCIENCE CONTENT ASSESSED BY GRADE 8 FCAT 2.0 SCIENCE

Big Idea 18 Matter and Energy Transformations		
Grade 6 Benchmark	Grade 7 Benchmark	Grade 8 Benchmark
		<p>SC.8.L.18.3 Construct a scientific model of the carbon cycle to show how matter and energy are continuously transferred within and between organisms and their physical environment.</p> <p style="text-align: right;">Assessed as SC.8.L.18.4.</p>
		<p>SC.8.L.18.4 Cite evidence that living systems follow the Laws of Conservation of Mass and Energy.</p> <p style="text-align: right;">Also assesses SC.8.L.18.1, SC.8.L.18.2, and SC.8.L.18.3.</p> <p>AA MC</p>

AA = annually assessed benchmark
MC = multiple choice

Standards marked as *Not Assessed* are more appropriately assessed through classroom instruction.

APPENDIX C: FCAT 2.0 SCIENCE ITEM WRITER GLOSSARY GRADE 5

The following glossary is a reference list provided for the item writers and is **not** intended to comprise a comprehensive vocabulary list for students. The definitions are not intended to provide a thorough scientific definition of the terms. Some definitions are limited by the extent of knowledge intended for the grade level. The terms and definitions in this glossary are specific to the Florida NGSSS in science for Grades 3 through 5 and the content assessed on FCAT 2.0 Science.

Absorb—To take up and store energy without reflecting or transmitting that energy.

Adaptation—A characteristic of an organism that increases its chances of survival in its environment.

Analyze—To examine methodically by separating into parts and studying their interrelatedness.

Asteroid—An object that is found in the solar system, orbits the Sun, and is much smaller than a planet.

Attraction—A term used to describe the magnetic force exerted by oppositely charged objects or to describe the gravitational force that pulls objects toward each other.

Balanced forces—Forces that are equal in size but opposite in direction. See also force and unbalanced forces.

Behavior—A plant or animal action, reaction, or activity that occurs in response to stimuli (e.g., gravity, light, temperature).

Carnivore—An animal that obtains nutrients from eating other animals.

Characteristic—A feature, quality, property, or trait of an object or organism.

Chemical change—Process by which substances are changed into different substances with different properties.

Classify—To arrange in a specific order or group by categories based on similarities.

Cleavage—A property used to describe how easily a mineral breaks apart along smooth surfaces.

Climate—The average pattern of weather that occurs in a certain location over many years.

Comet—An object made of rock, ice, dust, and gas that revolves around the Sun.

APPENDIX C: FCAT 2.0 SCIENCE ITEM WRITER GLOSSARY GRADE 5

Community—Populations of different species of organisms living together in the same geographic area.

Complete metamorphosis—Type of insect development characterized by the presence of a larval stage with different feeding habits.

Conclusion—A statement that tells what an investigation showed, based on observations and data.

Condensation—The process by which water is changed from a gas (water vapor) to a liquid; a stage of the water cycle.

Conduct—To transmit heat or electricity through a medium.

Consumer—An organism in a food chain that obtains nutrients from producers or other consumers; consumers may be herbivores or carnivores.

Control group—A group in a scientific experiment that serves as a reference for comparison to the experimental group; a group that is untreated by the factor being tested.

Data—Measurements or observations collected and recorded in an experiment or investigation.

Ecosystem—All the living and nonliving things that interact with each other in an environment.

Endangered species—A species whose population is so small that it is in danger of extinction.

Environment—An area that includes all living organisms and the surrounding physical features such as air, water, soil, weather, and landforms.

Erosion—The process by which rock, soil, and other weathered earth materials are moved from one place to another.

Evaporation—The process by which water is changed from a liquid to a gas (water vapor); a stage of the water cycle.

Experiment—A scientific test or procedure that is carried out under controlled conditions to answer a scientific question.

Extinct species—A species that no longer exists.

Fertilization—The process by which the female reproductive cell (egg) is united with the male reproductive cell (sperm or pollen).

APPENDIX C: FCAT 2.0 SCIENCE ITEM WRITER GLOSSARY GRADE 5

Food chain—A diagram representing the transfer of energy from the Sun through producers and a series of consumers.

Force—A push or a pull that one object exerts on another object with or without direct contact (e.g., friction, gravity). See also balanced forces and unbalanced forces.

Friction—A force that opposes motion through direct contact.

Germination—The process by which plants begin to grow from seed to spore or from seed to bud.

Hardness—A property of a mineral that describes how easily it can be scratched.

Hemisphere—Half of Earth (i.e., Northern, Southern, Eastern, Western).

Herbivore—An animal that obtains nutrients only from plants.

Humidity—A measure of the amount of water vapor in the air.

Igneous rock—A type of rock that forms from cooled magma or lava.

Incomplete metamorphosis—Type of insect development characterized by the similar appearance of pre-adults and adults.

Inference—An explanation based on evidence that is not directly observed.

Inherited trait—A trait or characteristic that is passed from parent to offspring.

Insulator—A material used to reduce or prevent the transfer of electricity, heat, or sound.

Invertebrate—An animal that lacks a backbone.

Investigation—An organized scientific study of the natural world that may include making systematic observations, asking questions, gathering information, analyzing data, summarizing results, drawing conclusions, and/or communicating results.

Larva—An early stage in the life cycle of an organism that will undergo complete metamorphosis.

Life cycle—The stages of an organism's growth and development.

Luster—A property of a mineral that describes how it appears when it reflects light.

Mass—The amount of matter a substance or object has.

APPENDIX C: FCAT 2.0 SCIENCE ITEM WRITER GLOSSARY GRADE 5

Matter—Anything that takes up space and has mass.

Mechanical energy—A type of energy an object has due to its motion or position.

Metamorphic rock—A type of rock that is formed over time from existing rock due to extreme pressure and/or heat.

Mineral—A solid material formed in nature on or in Earth's crust with its own properties.

Moon—A natural object that orbits a planet.

Nutrient—A substance that an organism needs to survive and grow.

Nymph—A pre-adult insect undergoing incomplete metamorphosis.

Observation—Information about the natural world gathered through the senses and/or scientific instruments.

Omnivore—An organism that obtains nutrients from both plants and animals.

Organism—A living thing.

Ovary—The female reproductive organ that produces and contains egg cells.

Physical change—A type of change that involves the physical properties of a substance.

Pistil—The female reproductive structure of a flowering plant.

Pitch—The relative frequency (high or low) of a sound as perceived by a listener.

Planet—A large body in space that orbits a star and does not produce its own light.

Polar zone—A climate zone characterized by very little precipitation and extremely cold temperatures.

Pollen—The fine dustlike powder that contains the male reproductive cells of seed-bearing plants.

Pollinate—To transfer the pollen from the male reproductive structure to the female reproductive structure to fertilize flowering plants.

Population—All members of the same species living together at the same time in the same area.

APPENDIX C: FCAT 2.0 SCIENCE ITEM WRITER GLOSSARY GRADE 5

Precipitation—A form of water (e.g., hail, rain, sleet, snow) that condenses in the atmosphere and falls to Earth’s surface.

Predator—An organism that obtains nutrients from other organisms.

Predict—To state what one thinks will happen under certain conditions based on data or observation.

Prey—An organism that is hunted and/or eaten by another organism (predator).

Producer—An organism that produces its own food.

Pupa—A stage in the life cycle of an insect that occurs between larva and adult.

Reflect—To bounce light, sound, or heat off of a surface.

Repel—To force away or apart.

Reproduction—The process of making more organisms of the same kind.

Revolution—The motion of one object around another object.

Rotation—The turning of an object on its axis.

Sedimentary rock—A type of rock formed from layers of sediment.

Soil—The loose top layer of Earth’s surface made of weathered rock and organic matter.

Solar system—A system of planets and other bodies that orbits a star.

Species—A group of the same kind of organisms that can mate and produce offspring that can reproduce.

Speed—The distance traveled by an object in a given amount of time.

Spore—A seedlike structure that produces a new plant (e.g., ferns or mosses).

Stamen—The male reproductive structure of a flowering plant.

Star—A large object in space that is made of gas and produces its own light.

State of matter—The form matter can take (e.g., solid, liquid, gas).

Streak—The color of the powder of a mineral when it is rubbed on a streak plate.

APPENDIX C: FCAT 2.0 SCIENCE ITEM WRITER GLOSSARY GRADE 5

Technology—The use of scientific knowledge and processes to solve practical problems.

Temperate zone—A climate zone located between the tropics and the polar circles generally characterized by moderate temperatures rather than extremely hot or cold temperatures.

Testable (scientifically testable)—A term used to describe a question that can be answered through an experiment or observation.

Texture—A physical property of a solid used to describe its surface.

Trials—Multiple sets of measurements or observations in a scientific investigation.

Tropical zone—A climate zone near the equator characterized by warm temperatures.

Unbalanced forces—Forces that are unequal in size and may or may not be opposite in direction. See also balanced forces and force.

Valid—A term used to describe the certainty of data or results of an investigation or experiment.

Variable—An event, condition, or factor that can be changed or controlled in order to study or test a hypothesis in a scientific experiment.

Vertebrate—An animal that has a backbone.

Volume—The amount of space an object or substance occupies.

Water cycle—The continuous movement of water through the environment by evaporation, condensation, precipitation, and runoff.

Water vapor—The gas state of water.

Weather—The condition of the atmosphere at a given time and place.

Weathering—The process by which rocks and other surfaces are broken down.

Weight—A measure of the force of gravity on an object.

APPENDIX C: FCAT 2.0 SCIENCE ITEM WRITER GLOSSARY GRADE 8

The following glossary is a reference list provided for the item writers and is **not** intended to comprise a comprehensive vocabulary list for students. The definitions are not intended to provide a thorough scientific definition of the terms. Some definitions are limited by the extent of knowledge intended for the grade level. The terms and definitions in this glossary are specific to the Florida NGSSS in science for Grades 6 through 8 and the content assessed on FCAT 2.0 Science. Knowledge of the terms in the Glossary for Grade 5 is assumed.

Acceleration—The rate at which velocity is changing. The change may involve an increase or decrease in speed and/or a change in direction. The change may be positive or negative.

Allele—Any of two or more alternate forms of a gene that an organism may have for a particular trait.

Amplitude—The maximum absolute variation of any periodic function (e.g., a wave).

Astronomical unit—A unit used to measure distances in the solar system equal to the average distance between the Sun and Earth, approximately 150 million kilometers, and abbreviated AU.

Autotroph—An organism that can produce food from inorganic materials (e.g., carbon dioxide, sunlight, water).

Binary fission—An asexual reproductive process in which a single cell divides into two cells.

Binomial nomenclature—A system used to name organisms using two words: the genus name and the species name.

Boiling point—The temperature at which a liquid changes to a gas. The boiling point of water at sea level is 100°C (212°F).

Budding—An asexual reproductive process in which an outgrowth of a parent organism detaches and forms a new individual of the same species.

Chemical properties—Characteristics of substances that describe their composition, reactivity, and how the substance changes into different substances.

Controlled variable—A factor or condition in a scientific experiment that is purposefully kept the same.

Dominant—The form of a trait that is expressed or shown when the combination of alleles for this trait is heterozygous.

Dwarf planet—A celestial body similar to a planet but orbiting in a zone that has many other objects in it (e.g., Ceres, Pluto).

APPENDIX C: FCAT 2.0 SCIENCE ITEM WRITER GLOSSARY GRADE 8

Empirical evidence—Evidence based on observations or experiments rather than theory.

Eukaryote—An organism whose cells contain a nucleus surrounded by a membrane.

Evolution (scientific theory of evolution)—A cumulative change in the characteristics of organisms or populations over time from generation to generation.

F₁ generation—The first generation of offspring from the mating of parental organisms (P generation).

Fault—A crack in Earth’s crust along which movement has occurred.

Fold—A bend in a layer or several layers of rock.

Heterogeneous—A type of mixture in which different parts can be easily distinguished.

Heterotroph—An organism that cannot produce its own food.

Heterozygous—A cell or organism that has two different alleles for a particular trait.

Homeostasis—The tendency of a cell, organism, or population to maintain internal stability.

Homogeneous—A type of mixture in which the different parts are blended evenly so that the mixture is the same throughout.

Homozygous—A type of cell or organism that has identical rather than different alleles for a particular trait.

Hypothesis—A statement that can be tested scientifically through experiments and/or other scientific investigations.

Infiltration—A process in which water soaks into the soil.

Kingdom—The highest Linnaean classification into which organisms are grouped; above phylum.

Law (scientific law)—A scientific principle based on many observations of naturally occurring events that demonstrate it to be without exception under certain stated conditions. See also theory.

Light-year—The distance a ray of light travels in a vacuum in one year.

Melting point—The temperature at which a solid changes to a liquid. The melting point of ice at sea level is 0°C (32°F).

APPENDIX C: FCAT 2.0 SCIENCE ITEM WRITER GLOSSARY GRADE 8

Model (scientific model)—A replica or description designed to show the workings or structure of an object or system.

Molecule—The smallest unit of matter of a substance that retains all the physical and chemical properties of that substance; consists of a single atom or a group of atoms bonded together.

Nebula—A large cloudlike mass of gas and dust in space that may lead to the formation of a star.

Net force—The sum of all the forces acting on an object. When forces are balanced, the net force is zero and the object's motion will remain the same. When forces are unbalanced, the net force is nonzero and the object's motion will change.

Niche—The unique position occupied by a particular species in terms of the area it inhabits and the function it performs within the community.

Nucleus—The center region of an atom where protons and neutrons are located; also, the cell structure that contains a cell's genetic material.

Opaque—A term used to describe a material that absorbs and/or reflects light and does not allow light to pass through.

Outcome variable (dependent variable)—A factor, usually being measured or observed, that responds to, or depends on, another factor (test variable).

P generation—The parental generation in a genetic cross.

Percolation—The movement of water through rock or soil.

pH—A measure of the acidity or alkalinity of a solution based on a scale from zero to fourteen.

Pressure—The force exerted per unit area.

Prokaryote—An organism whose cells are characterized by the lack of a defined nucleus.

Recessive—The form of a trait that will be masked unless the organism is homozygous for this trait.

Regeneration—The growth of new tissues or organs to replace those lost or damaged by injury.

Repetition—Making multiple sets of measurements or observations in a scientific investigation.

APPENDIX C: FCAT 2.0 SCIENCE ITEM WRITER GLOSSARY GRADE 8

Replication—The reproduction of a scientific investigation by another person to ensure accuracy.

Saturation—A condition of a solution whereby it has reached a maximum amount of solute under the given conditions.

Solute—A substance that is being dissolved by another substance.

Solvent—A substance that dissolves another substance.

Systematic observations—Observations obtained by following a preplanned method of observation.

Temperature—A measure of how hot or cold a substance is; a measure of the average kinetic energy of the particles of a substance.

Test variable (independent variable)—The variable manipulated by the experimenter in order to study changes in the outcome variable.

Theory (scientific theory)—An explanation for some naturally occurring event developed from extensive observations, experimentation, and reasoning. See also law.

Translucent—A term used to describe a material that cannot be clearly seen through but that allows some light to pass through it.

Transparent—A term used to describe a material that can be clearly seen through because it allows light waves to pass through in straight lines.

Periodic Table of the Elements

(based on $^{12}_6\text{C} = 12.0000$)

Group												Representative Elements					
1	2											13	14	15	16	17	18
1A	2A											3A	4A	5A	6A	7A	8A
1 H Hydrogen 1.008																	He Helium 4.003
2 Li Lithium 6.941	Be Beryllium 9.012	Transition Metals										B Boron 10.81	C Carbon 12.011	N Nitrogen 14.007	O Oxygen 15.999	F Fluorine 18.998	Ne Neon 20.180
3 Na Sodium 22.990	Mg Magnesium 24.305	3 B	4 B	5 B	6 B	7 B	8 B	9 B	10 B	11 B	12 B	Al Aluminum 26.982	Si Silicon 28.086	P Phosphorus 30.974	S Sulfur 32.06	Cl Chlorine 35.453	Ar Argon 39.948
4 K Potassium 39.098	Ca Calcium 40.078	Sc Scandium 44.956	Ti Titanium 47.88	V Vanadium 50.942	Cr Chromium 51.996	Mn Manganese 54.938	Fe Iron 55.847	Co Cobalt 58.933	Ni Nickel 58.693	Cu Copper 63.546	Zn Zinc 65.39	Ga Gallium 69.723	Ge Germanium 72.61	As Arsenic 74.922	Se Selenium 78.96	Br Bromine 79.904	Kr Krypton 83.80
5 Rb Rubidium 85.468	Sr Strontium 87.62	Y Yttrium 88.906	Zr Zirconium 91.224	Nb Niobium 92.906	Mo Molybdenum 95.94	Tc Technetium 98	Ru Ruthenium 101.07	Rh Rhodium 102.906	Pd Palladium 106.42	Ag Silver 107.868	Cd Cadmium 112.411	In Indium 114.82	Sn Tin 118.710	Sb Antimony 121.757	Te Tellurium 127.60	I Iodine 126.905	Xe Xenon 131.29
6 Cs Cesium 132.905	Ba Barium 137.327	La Lanthanum 138.905	Hf Hafnium 178.49	Ta Tantalum 180.948	W Tungsten 183.85	Re Rhenium 186.207	Os Osmium 190.2	Ir Iridium 192.22	Pt Platinum 195.08	Au Gold 196.967	Hg Mercury 200.59	Tl Thallium 204.383	Pb Lead 207.2	Bi Bismuth 208.980	Po Polonium 208.982	At Astatine 210	Rn Radon 222
7 Fr Francium 223	Ra Radium 226.025	Ac Actinium 227.028	Rf Rutherfordium (261)	Db Dubnium (262)	Sg Seaborgium (263)	Bh Bohrium (264)	Hs Hassium (265)	Mt Meitnerium (268)									

14 — Atomic number
Si — Symbol
 Silicon — Name
 28.086 — Average Atomic Mass

← Metals Nonmetals →

Inner Transition Metals

Lanthanide series

58 Ce Cerium 140.12	59 Pr Praseodymium 140.908	60 Nd Neodymium 144.24	61 Pm Promethium 144.913	62 Sm Samarium 150.36	63 Eu Europium 151.96	64 Gd Gadolinium 157.25	65 Tb Terbium 158.925	66 Dy Dysprosium 162.50	67 Ho Holmium 164.930	68 Er Erbium 167.26	69 Tm Thulium 168.934	70 Yb Ytterbium 173.04	71 Lu Lutetium 174.967
-------------------------------------	--	--	--	---------------------------------------	---------------------------------------	---	---------------------------------------	---	---------------------------------------	-------------------------------------	---------------------------------------	--	--

90 Th Thorium 232.038	91 Pa Protactinium 231.036	92 U Uranium 238.029	93 Np Neptunium 237.048	94 Pu Plutonium 244.064	95 Am Americium 243.061	96 Cm Curium 247.070	97 Bk Berkelium 247.070	98 Cf Californium 251.080	99 Es Einsteinium 252.083	100 Fm Fermium 257.095	101 Md Mendelevium 258.099	102 No Nobelium 259.101	103 Lr Lawrencium 260.105
---------------------------------------	--	--------------------------------------	---	---	---	--------------------------------------	---	---	---	--	--	---	---

Actinide series

APPENDIX D: PERIODIC TABLE OF THE ELEMENTS
GRADE 8 AND BIOLOGY 1 EOC ASSESSMENT

APPENDIX E: FCAT 2.0 SCIENCE AND BIOLOGY 1 END-OF-COURSE ASSESSMENT TEST DESIGN SUMMARY

Length of Tests

This table provides an approximate range for the number of items on each test. These ranges include both the operational and field-test items.

Grade	Item Range
5	60–66
8	60–66
Biology 1	60–66



The Florida Department of Education and its test contractors currently employ strategies to protect the environment in the production and destruction of FCAT materials. The Department encourages schools and districts to recycle non-secure FCAT interpretive publications after use.